

# Olivine Estate

## Stage 4

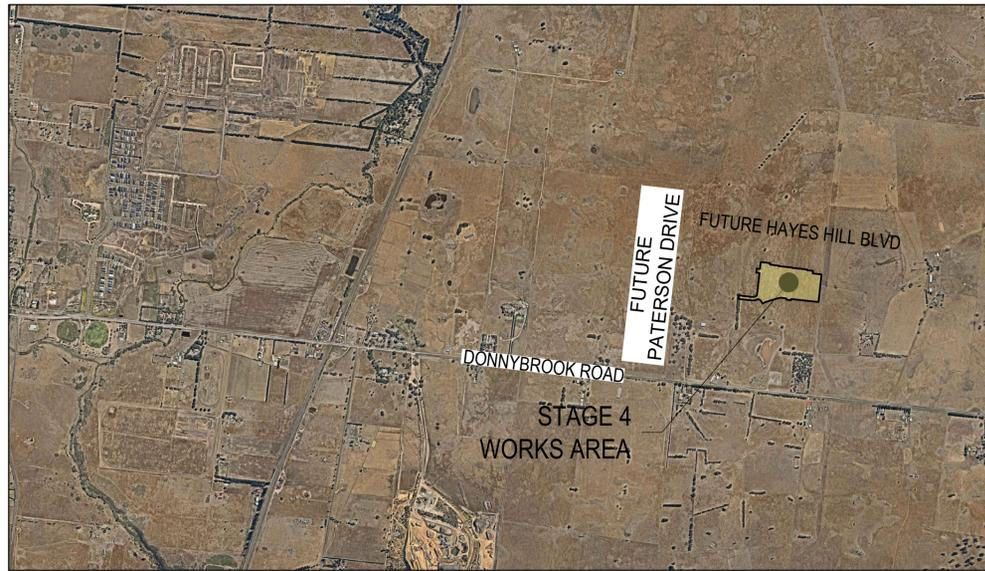

### GENERAL NOTES (WHITTLESEA CITY COUNCIL)

- THE WORKS SHALL BE CONSTRUCTED IN ACCORDANCE WITH THE VPA MANUAL AND SPECIFICATIONS. WORKS TO BE CARRIED OUT TO THE SATISFACTION OF COUNCIL'S SUPERVISING OFFICER.
- THE CONTRACTOR IS RESPONSIBLE FOR SAFETY OF WORK ON SITE IN ACCORDANCE WITH APPROPRIATE LEGISLATION. THEY SHALL ERECT AND MAINTAIN ALL SHORING, PLANKING AND STRUTTING, DEWATERING DEVICES, BARRICADES, SIGNS, LIGHTS, ETC. NECESSARY TO KEEP WORKS IN A SAFE AND STABLE CONDITION, AND TO PROTECT THE PUBLIC FROM HAZARDS ASSOCIATED WITH THE WORKS.
- THE CONTRACTOR SHALL:
  - COMPLY WITH THE SAFETY REQUIREMENTS OF THE MINES ACT, GENERAL REGULATIONS AND STATUTORY RULES, AND THE MINES (TRENCHES) REGULATIONS 1982.
  - NOTIFY THE OCCUPATIONAL HEALTH AND SAFETY AUTHORITY OF HIS INTENTION TO COMMENCE TRENCHING OPERATIONS WHERE TRENCHES ARE 1.5 METRES OR DEEPER.
  - ENSURE THAT THE MINE MANAGER OR HIS DEPUTY AS REQUIRED BY THE REGULATIONS IS IN ATTENDANCE WHEN TRENCHING OPERATIONS ARE IN PROGRESS.
- THE CONTRACTOR IS TO NOTIFY COUNCIL AND ALL SERVICE AUTHORITIES SEVEN (7) DAYS PRIOR TO COMMENCEMENT OF CONSTRUCTION.
- THE LOCATION OF EXISTING SERVICES SHOULD BE DETERMINED BY THE CONTRACTOR PRIOR TO COMMENCING ANY EXCAVATION BY CONTACTING ALL RELEVANT SERVICE AUTHORITIES. ANY EXISTING SERVICES SHOWN ON THE DRAWINGS ARE OFFERED AS A GUIDE ONLY AND ARE NOT GUARANTEED AS CORRECT.
- REDGUM TREES MARKED ON THE APPROVED PLANS FOR REMOVAL MUST BE REMOVED IN ACCORDANCE WITH COUNCIL'S PLANNING PERMIT. NO EXCAVATION SHALL BE CARRIED OUT WITHIN 5.0m OF ANY EXISTING TREE WITHOUT WRITTEN APPROVAL FROM COUNCIL'S SUPERVISING OFFICER.
- ALL ROAD CHAINAGES ARE MEASURED ALONG THE ROAD CENTRELINE EXCEPT KERB RETURNS AND COURTHHEADS, WHERE LIP OF KERB CHAINAGES ARE SPECIFIED. ALL DIMENSIONS AND RADII ARE GIVEN TO THE LIP OF KERB. DO NOT SCALE OFF THESE DRAWINGS, WRITTEN DIMENSIONS ONLY SHALL BE USED.
- ALL LEVELS ARE TO AUSTRALIAN HEIGHT DATUM.
- WHEN ENGAGED IN BLASTING OPERATIONS THE CONTRACTOR SHALL NOT BLAST WITHIN 4.5m OF AN EXISTING LINE OF WATER, GAS OR SEWER PIPES OR WITHIN 15m OF ANY COMPLETED PART OF THE WORKS WITHOUT THE CONSENT OF THE SUPERINTENDENT. BLASTING REQUIRES A BLASTING PERMIT FROM COUNCIL.
- ALL EXCAVATED OR FILLED AREAS OUTSIDE THE ROAD RESERVES TO BE STRIPPED OF TOPSOIL AND STOCKPILED PRIOR TO EARTHWORKS COMMENCING. THESE AREAS SHALL BE SURFACED WITH A 100mm MINIMUM TO 200mm MAXIMUM LAYER OF TOPSOIL AS SPECIFIED.
- NO TOPSOIL TO BE REMOVED FROM SITE.
- NO FILL OR STOCKPILING OF MATERIAL IS TO BE PLACED ON ANY RESERVE UNLESS DIRECTED BY THE SUPERINTENDENT.
- FILLING ON ALLOTMENTS AND UNDER ROAD PAVEMENTS TO HAVE LEVEL 1 SUPERVISION IN ACCORDANCE WITH AS3798-1996. INDIVIDUAL LOT CERTIFICATES ARE TO BE PROVIDED TO THE SUPERINTENDENT.
- FILLING UNDER DRIVEWAYS AND FOOTPATH IS TO BE APPROVED BY THE SUPERINTENDENT AND CONSTRUCTED IN LAYERS 150mm DEPTH. COMPACTION ACHIEVING 98% AUSTRALIAN STANDARD DENSITY.
- CUT AND FILL BATTERS ARE NOT TO EXCEED 1 in 6 UNLESS SHOWN OTHERWISE.
- ALLOTMENTS TO BE GRADED TO ENSURE A MINIMUM GRADE OF 1 in 150.
- ALL DRAINAGE PIPES UP TO AND INCLUDING 750mm IN DIAMETER SHALL BE RUBBER RING JOINTED. PIPES ABOVE THIS SIZE MUST BE FLUSH JOINTED WITH EXTERNAL SEALING BANDS.
- ALL DRAINAGE TRENCHES UNDER ROAD PAVEMENTS, KERB & CHANNEL, PARKING BAYS, DRIVEWAYS, FOOTPATHS AND BEHIND KERBS & CHANNEL SHALL BE BACKFILLED WITH CRUSHED ROCK AS SPECIFIED.
- ALL PITS GREATER THAN OR EQUAL TO 900mm DEPTH TO BE PROVIDED WITH STEP IRONS IN ACCORDANCE WITH SD1041 AND COUNCIL STANDARD DRAWING EDM 609.
- PROPERTY INLETS AS PER WHITTLESEA CITY COUNCIL STANDARD DRAWING EDM 701-704 AND ARE TO BE LOCATED 1.0m FROM LOW SIDE BOUNDARY UNLESS SHOWN OTHERWISE.
- ALL HOUSE DRAIN CONNECTIONS ARE TO BE LOCATED NO CLOSER THAN 7.0m FROM THE SIDE BOUNDARY OR FROM EASEMENT ALONG THE SIDE BOUNDARY UNLESS NOTED OTHERWISE AND CONNECTED DIRECTLY TO UNDERGROUND DRAIN OR PIT. HOUSE DRAIN LOCATION TO BE MARKED (50mm STAMPED IMPRESSION) ON THE TOP OF THE KERB.
- SUBSOIL DRAINS SHALL BE INSTALLED BEHIND OR BELOW ALL KERB AND CHANNEL AS PER STANDARD DRAWING EDM 202.
- CONDUIT LOCATIONS ARE SUBJECT TO AMENDMENT AND CONDUITS SHALL NOT BE LAID UNTIL WRITTEN APPROVAL IS GIVEN BY THE SUPERINTENDENT. CONDUITS TO BE EXTENDED TO PROPERTY LINE AND ARE REQUIRED WHEN CONNECTIONS EXTEND UNDER ROAD PAVEMENT, FOOTPATH OR OTHER INFRASTRUCTURE. BOTH KERBS ARE TO BE MARKED WITH THE LETTERS H (PROPERTY STORMWATER CONNECTION), E (ELECTRICAL), G (GAS), T (TELEPHONE), W (WATER) AND C (COUNCIL COMMUNICATION) AS PER STANDARD DRAWING EDM 303.
- ALL SERVICING TRENCHES UNDER ROADS, DRIVEWAYS, FOOTPATHS ETC. ARE TO BE BACKFILLED & COMPACTED WITH F.C.R. IN THE CASE OF TRENCHES UNDER ROADS WHERE BACKFILLING HAS NOT ACHIEVED THE SPECIFIED COMPACTION OR SHOWS EXCESSIVE MOVEMENT UNDER PROFFROLLING, THE BACKFILLING SHALL BE REMOVED AND REPLACED WITH 2% STABILISED COMPACTED F.C.R. ALL SERVICES ARE TO BE PLACED PRIOR TO THE CAPPING LAYER.
- NO TELSTRA PITS ARE TO BE LOCATED IN THE FOOTPATH.
- VEHICULAR CROSSINGS TO BE LOCATED CLEAR OF DRAINAGE PITS, SEWER MAINTENANCE HOLES AND EXISTING TREES. VEHICLE CROSSINGS TO BE 1.5m FROM PROPERTY BOUNDARY OR EASEMENT UNLESS OTHERWISE SHOWN. VEHICULAR CROSSINGS TO BE CONSTRUCTED AS PER WHITTLESEA CITY COUNCIL'S SPECIFICATIONS AND EDM 501 TO 503.
- ALL PEDESTRIAN CROSSING THROUGH SPLITTER ISLANDS TO BE IN ACCORDANCE WITH SD606.
- ALL STREET SIGNS TO BE IN ACCORDANCE WITH SD812. STREET SIGNS TO BE ATTACHED TO LIGHT POLES USING 'SINGLE DIRECTION COLLAR' OR '90° RIGHT ANGLE COLLAR' UNLESS SHOWN OTHERWISE.
- ALL PAVEMENT MARKINGS AND TRAFFIC SIGNS SHOULD BE TO AS1742.2 AND AS1742.1 STANDARD RESPECTIVELY. TEMPORARY LINEMARKING TO BE PLACED DURING MAINTENANCE PERIOD PRIOR TO PLACEMENT OF WEARING COURSE. FINAL LINEMARKING TO BE LONG LIFE ROAD MARKING WITH LONGITUDINAL LINES IN THERMOPLASTIC AND TRANSVERSE MARKINGS IN COLD APPLIED.
- THE CAPPING LAYER MUST BE DEMONSTRATED THROUGH TESTING THAT ITS PROPERTIES (CBR, PERMEABILITY, ETC.) SATISFY LIMITS AS OUTLINED IN THE TECHNICAL SPECIFICATION TABLE 20.3.5B WITH A MINIMUM MODULUS OF 100MPa.
- UPON COMPLETION OF CONSTRUCTION THE WHOLE SITE SHALL BE CLEANED UP, GRADED, ALL RUBBISH REMOVED AND LEFT IN A CLEAN AND TIDY CONDITION TO THE SATISFACTION OF THE SUPERINTENDENT.
- ALL FOOTPATHS & SHARED PATHS ARE TO BE CONSTRUCTED IN ACCORDANCE WITH EDM 401.

### Drawing Index

- 1700E-04-01 Cover Plan
- 1700E-04-02 Layout Plan - 1
- 1700E-04-03 Layout Plan - 2
- 1700E-04-04 Typical Cross Sections
- 1700E-04-05 Longitudinal Sections - 1
- 1700E-04-06 Longitudinal Sections - 2
- 1700E-04-07 Longitudinal Sections - 3
- 1700E-04-08 Longitudinal Sections - 4
- 1700E-04-09 Cross Sections: Olivine Boulevard Ch 859.59 - Ch 994.09
- 1700E-04-10 Cross Sections: Olivine Boulevard Ch 1008.09 - Ch 1054.09
- 1700E-04-11 Cross Sections: Olivine Boulevard Ch 1068.09 - Ch 1094.59
- 1700E-04-12 Cross Sections: Cycad Avenue Ch 165.30 - Ch 236.95
- 1700E-04-13 Cross Sections: Cycad Avenue Ch 252.10 - Ch 430.41
- 1700E-04-14 Cross Sections: Cycad Avenue Ch 496.02 - Ch 537.54
- 1700E-04-15 Cross Sections: Cycad Avenue Ch 550.04 - Ch 578.04
- 1700E-04-16 Cross Sections: Cycad Avenue Ch 590.54 - Ch 634.14
- 1700E-04-17 Cross Sections: Grammar Avenue
- 1700E-04-18 Cross Sections: Academy Lane & Oriol Road
- 1700E-04-19 Cross Sections: Degree Lane & Hub Lane
- 1700E-04-20 Cross Sections: Faculty Avenue
- 1700E-04-21 Cross Sections: Conservatory Street
- 1700E-04-22 Cross Sections: Institute Drive & Foundation Avenue
- 1700E-04-23 Intersection Detail Plan & Lip Profiles - 1
- 1700E-04-24 Intersection Detail Plan & Lip Profiles - 2
- 1700E-04-25 Intersection Detail Plan & Lip Profiles - 3
- 1700E-04-26 Intersection Detail Plan & Lip Profiles - 4
- 1700E-04-27 Intersection Detail Plan & Lip Profiles - 5
- 1700E-04-28 Intersection Detail Plan & Lip Profiles - 6
- 1700E-04-29 Intersection Detail Plan & Lip Profiles - 7
- 1700E-04-30 Drainage Longitudinal Sections - 1
- 1700E-04-31 Drainage Longitudinal Sections - 2
- 1700E-04-32 Drainage Longitudinal Sections - 3
- 1700E-04-33 Drainage Longitudinal Sections - 4
- 1700E-04-34 Drainage Longitudinal Sections - 5
- 1700E-04-35 Drainage Longitudinal Sections - 6
- 1700E-04-36 Drainage Longitudinal Sections - 7
- 1700E-04-37 Drainage Pit Schedule
- 1700E-04-38 Signage & Linemarking Plan - 1
- 1700E-04-39 Signage & Linemarking Plan - 2
- 1700E-04-40 General Notes & Details
- 1700E-04-41 Pavement Details
- 1700E-04-42 Concrete Jointing Details
- 1700E-04-43 Earthworks & Retaining Wall Setout Plan
- 1700E-04-44 Retaining Wall Longitudinal Sections
- 1700E-04-85 Safety In Design

ROAD NAME	SERVICES OFFSET SCHEDULE									
	GAS		NON-DRINKING WATER		DRINKING WATER		ELECTRICITY		NBN	
	SIDE	OFFSET (m)	SIDE	OFFSET (m)	SIDE	OFFSET (m)	SIDE	OFFSET (m)	SIDE	OFFSET (m)
OLIVINE BL (ADJACENT LOTS & LOCAL OPEN SPACE)	EAST	2.10	EAST	2.60	EAST	3.10	WEST	1.40	WEST	0.40
OLIVINE BL (ADJACENT LOTS & SCHOOL)	EAST	2.10	EAST	2.60	EAST	3.10	WEST	4.30	WEST	3.60
CYCAD AVENUE (WEST OF OLIVINE BOULEVARD)	NORTH	3.60	NORTH	4.00	NORTH	4.50	SOUTH	1.20	SOUTH	0.40
CYCAD AVENUE (EAST OF OLIVINE BOULEVARD)	SOUTH	2.10	SOUTH	2.60	SOUTH	3.10	NORTH	3.95	NORTH	3.35
CYCAD AVENUE (ADJACENT OPEN SPACE)	SOUTH	2.10	SOUTH	2.60	SOUTH	3.10	NORTH	0.95	NORTH	0.35
ORIEL ROAD (ADJACENT GAS EASEMENT)	WEST	2.10	WEST	2.50	WEST	3.00	EAST	1.50	EAST	0.70
CONSERVATORY STREET	SOUTH	2.10	SOUTH	2.50	SOUTH	3.00	NORTH	2.35	NORTH	1.85
INSTITUTE DRIVE (ADJACENT GAS EASEMENT)	WEST	2.10	WEST	2.50	WEST	3.00	EAST	1.50	EAST	0.70
ACADEMY LANE	EAST	2.10	EAST	2.50	EAST	3.00	WEST	2.65	WEST	1.85
GRAMMAR AVENUE (ADJOINING OPEN SPACE)	WEST	2.10	WEST	2.50	WEST	3.00	EAST	0.95	EAST	0.35
GRAMMAR AVENUE	WEST	2.10	WEST	2.50	WEST	3.00	EAST	2.35	EAST	1.85
FACULTY AVENUE	WEST	2.10	WEST	2.50	WEST	3.00	EAST	2.35	EAST	1.85
DEGREE LANE	NORTH	1.80	NORTH	2.20	NORTH	2.70	NORTH	3.70	NORTH	3.20
HUB LANE	NORTH	1.80	NORTH	2.20	NORTH	2.70	NORTH	3.70	NORTH	3.20
FOUNDATION AVENUE	EAST	2.10	EAST	2.50	EAST	3.00	WEST	2.35	WEST	1.85

\* STREET TREES TO BE PLANTED AT THE CENTRE OF THE NATURE STRIP

ROAD NAME	RESERVE WIDTH (m)	ROAD WIDTH TABLE							
		ROAD WIDTH (m)			KERB TYPE		VERGE WIDTH (m)		
		LIP to LIP	INV to INV	BACK to BACK	NTH/WEST	STH/EAST	NTH/WEST	STH/EAST	
OLIVINE BL (ADJACENT LOTS & LOCAL OPEN SPACE)	18.50	5.10	6.00	6.30	B2	B2	3.20	4.70	
OLIVINE BL (ADJACENT LOTS & SCHOOL)	22.00	5.10	6.00	6.30	B2	B2	6.45	4.95	
CYCAD AVENUE (WEST OF OLIVINE BOULEVARD)	19.50	5.10	6.00	6.30	B2	B2	6.25	2.65	
CYCAD AVENUE	21.50	6.40	7.30	7.60	B2	B2	9.50	4.70	
CYCAD AVENUE (ADJACENT OPEN SPACE)	14.50	6.40	7.30	7.60	B2	B2	2.35	4.55	
ORIEL ROAD (ADJACENT GAS EASEMENT)	15.00	6.40	7.30	7.60	B2	B2	4.35	3.35	
CONSERVATORY STREET	16.00	6.40	7.30	7.60	B2	B2	4.35	4.35	
INSTITUTE DRIVE (ADJACENT GAS EASEMENT)	15.00	6.40	7.30	7.60	B2	B2	4.35	3.35	
ACADEMY LANE	16.00	6.40	7.30	7.60	B2	B2	4.35	4.35	
GRAMMAR AVENUE (ADJOINING OPEN SPACE)	14.50	6.40	7.30	7.60	B2	B2	4.35	2.85	
GRAMMAR AVENUE	16.00	6.40	7.30	7.60	B2	B2	4.35	4.35	
FACULTY AVENUE (ADJOINING OPEN SPACE)	14.50	6.40	7.30	7.60	B2	B2	2.85	4.35	
FACULTY AVENUE	16.00	6.40	7.30	7.60	B2	B2	4.35	4.35	
DEGREE LANE	12.00	4.00	-	-	-	-	4.90	3.10	
HUB LANE	12.00	4.00	-	-	-	-	4.90	3.10	
FOUNDATION AVENUE	16.00	6.40	7.30	7.60	B2	B2	4.35	4.35	

TABLE 6: TBM SETOUT TABLE				
POINT	EAST	NORTHING	ELEVATION	DESCRIPTION
C34SSPL	323383.546	5842934.15	238.735	STEEL STAR PICKET
C68PM7L	323210.099	5842698.35	237.616	PERMANENT MARK PM77
C75PM50L	322900.181	5842750.808	240.178	PERMANENT MARK PM50
C76SSPL	323252.295	5842715.378	236.886	STEEL STAR PICKET
C77RVTRG	323038.436	5842738.371	243.696	RIVET IN ROCK
C78SSPG	322835.256	5842759.893	239.488	STEEL STAR PICKET
C79SSPL	322666.202	5842778.237	238.207	STEEL STAR PICKET
C80SPKBG	322654.654	5842776.01	238.428	SPIKE IN BITUMEN
C81SSPL	322549.258	5842791.748	235.563	STEEL STAR PICKET
C82SSPL	322570.163	5842989.303	236.275	STEEL STAR PICKET
C83SSPL	322595.579	5843198.908	239.115	STEEL STAR PICKET
C84RVTRL	322617.683	5843412.157	242.457	RIVET IN ROCK
C85SSPL	322640.995	5843611.461	239.572	STEEL STAR PICKET
C86SSPL	323276.817	5842944.336	237.989	STEEL STAR PICKET
C104RVTRL	322946.48	5843298.043	243.686	RIVET IN ROCK
C106SSPL	322762.605	5842991.952	238.464	STEEL STAR PICKET
C107SSPL	322900.731	5843023.612	240.323	STEEL STAR PICKET
C108SSPL	323208.79	5843072.045	241.058	STEEL STAR PICKET
C109SSPL	322932.732	5843474.686	243.559	STEEL STAR PICKET

**WARNING**  
**SAFETY MEASURES REQUIRED**  
 Please note there are risks attached to the construction of this project, and any ongoing maintenance of structures. Consider the safety of all. For potential risks, consequences and controls refer to Safety In Design Risk Register SID P4.E6. 1700E-04-01  
**ASSESS THE RISK - STAY SAFE**

**WARNING**  
**BEWARE OF UNDERGROUND SERVICES**  
 The locations of underground services are approximate only and their exact position should be proven on site. No guarantee is given that all existing services are shown. Locate all underground services before commencement of works  
**DIAL 1100 BEFORE YOU DIG**  
 www.1100.com.au

REV	DATE	AMENDMENT / REVISION DESCRIPTION	DESIGN	APPROVAL
0	05.10.18	ISSUED FOR CONSTRUCTION	PM/RB	AB

TITLE	NAME
DRAFTER	R.Barua
DESIGNER	P.McKay
CHECKED	Z.Gosev
AUTHORISED	A.Burrows
SMEC DRAWING REF.	1700E-04
MELBOURNE WATER REF.	388/3079

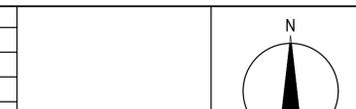

Olivine Estate - Stage 4 Whittlesea City Council Road and Drainage Cover Plan	
MELBOURNE REF <b>8 M2</b>	PROJECT / DRAWING No. <b>1700E-04-01</b>
SHEET No. <b>01 of 45</b>	REVISION <b>0</b>

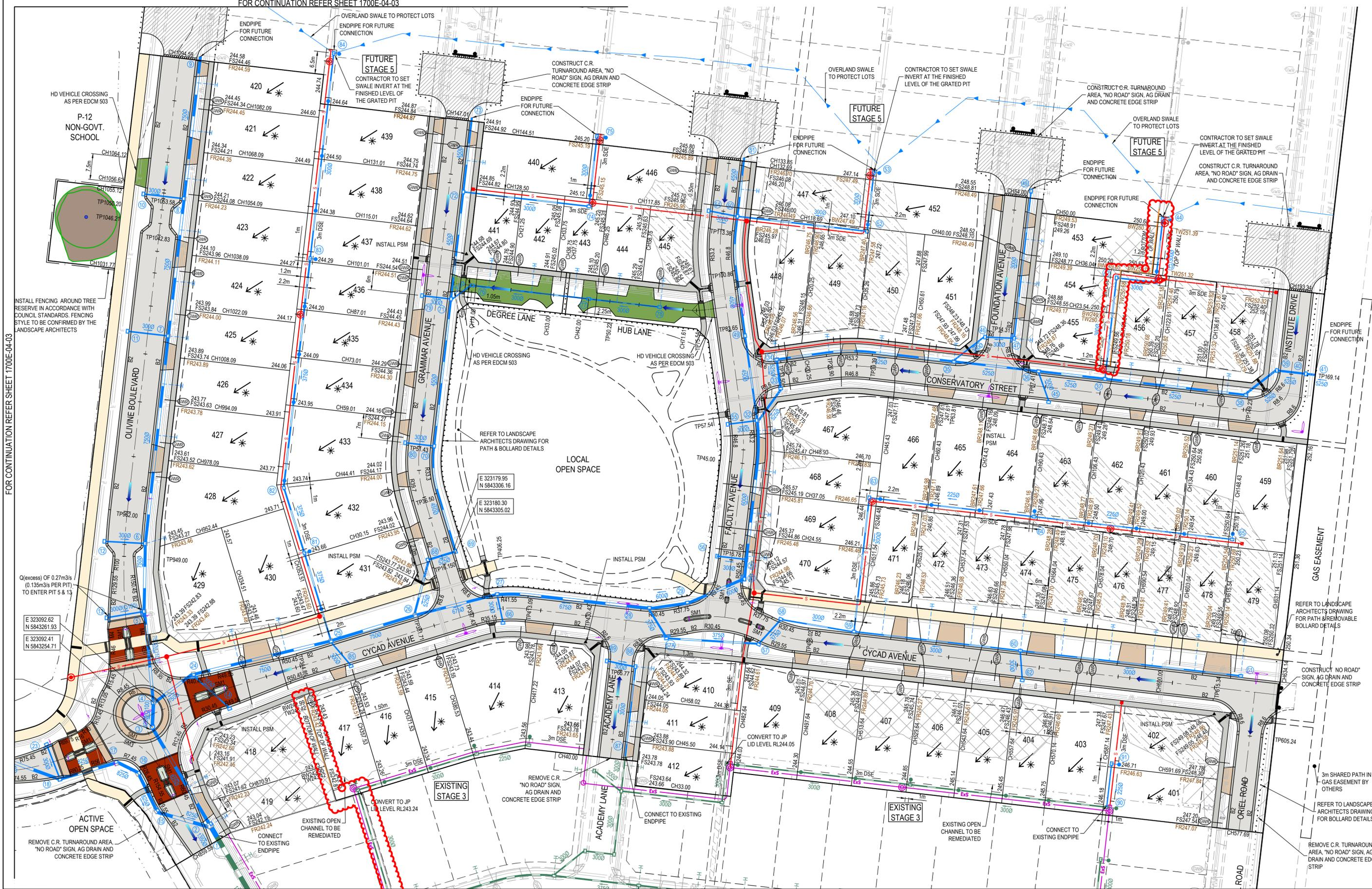

REV	DATE	AMENDMENT / REVISION DESCRIPTION	DESIGN	APPROVAL
0	05.10.18	ISSUED FOR CONSTRUCTION	PM/RB	AB

All setting out should be carried out in accordance with MPA/Council's standard drawings or as nominated on hard copy plans provided by SMEC. Any digital information supplied by this office is for information only. Any discrepancies should be discussed with the superintendent.

TITLE	NAME
DRAFTER	R.Barua
DESIGNER	P.McKay
CHECKED	Z.Gosev
AUTHORISED	A.Burrows
SMEC DRAWING REF.	1700E-04
MELBOURNE WATER REF.	388/3079

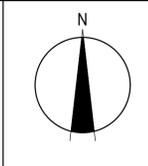

**SMEC**  
Member of the Surlana Jurong Group  
© ABN 47 065 475 149  
Tower 4, Level 20, 727 Collins Street  
Docklands, VIC 3008  
Ph 03 9514 1500

**mirvac**

Olivine Estate - Stage 4 Whittlesea City Council Road and Drainage Layout Plan - 1	
MELWAYS REF 8 M2	PROJECT / DRAWING No. 1700E-04-02
SHEET No. 02 of 45	REVISION 0

LEGEND - LAYOUT PLAN	
ALL PROPOSED, FUTURE & EXISTING SERVICE LOCATIONS ARE SHOWN INDICATIVELY	
	STORMWATER DRAIN, PIT & PROPERTY INLET
	SWALE DRAIN
	SEWER & MAINTENANCE STRUCTURES
	HOUSE DRAIN
	ELECTRICITY (U GROUND)
	ELECTRICITY (O HEAD)
	GAS
	TELSTRA
	WATER
	RECYCLE WATER
	AG. DRAIN
	SERVICE CONDUITS
	TACTILE PAVERS
	EXISTING STORMWATER DRAIN
	EXISTING MAIN DRAIN
	EXISTING SWALE DRAIN
	EXISTING SEWER & MAINTENANCE STRUCTURES
	EXISTING HOUSE DRAIN
	EXISTING ELECTRICITY (UNDER GROUND)
	EXISTING ELECTRICITY OVERHEAD
	EXISTING GAS
	EXISTING TELSTRA
	EXISTING WATER
	EXISTING RECYCLED WATER
	EXISTING AG. DRAIN
	EXISTING SERVICE CONDUITS
	EXISTING TACTILE PAVERS
	FUTURE STORMWATER DRAIN
	FUTURE MAIN DRAIN
	FUTURE SWALE DRAIN
	FUTURE SEWER & MAINTENANCE STRUCTURES
	FUTURE HOUSE DRAIN
	FUTURE ELECTRICITY (UNDER GROUND)
	FUTURE ELECTRICITY OVERHEAD
	FUTURE GAS
	FUTURE TELSTRA
	FUTURE WATER
	FUTURE RECYCLED WATER
	FUTURE AG. DRAIN
	FUTURE SERVICE CONDUITS
	ZERO LOT LINES
	141.34 EXISTING SURFACE LEVEL
	FS140.35 FINISHED BUILDING LINE LEVEL
	FR157.40 FINISHED RIDGE LINE LEVEL
	CH270.00 CHAINAGE
	TW159.60 TOP OF RETAINING WALL LEVEL
	BW159.00 BOTTOM OF RETAINING WALL LEVEL
	EXISTING RETAINING WALL
	RETAINING WALL
	FUTURE RETAINING WALL
	STRUCTURAL FILL > 200mm DEEP
	EXISTING STRUCTURAL FILL > 200mm DEEP
	CUT > 200mm DEEP
	DIRECTION OF FALL
	OVERLAND FLOW
	GRADED IN DIRECTION OF FALL TO LEVEL INDICATED
	EDGE STRIP, SUBSOIL DRAIN, 'NO ROAD' SIGN & BARRIER
	EXISTING TREE TO BE RETAINED
	PERMANENT SURVEY MARK
	TEMPORARY BENCH MARK
	PROPOSED DRIVEWAY & FOOTPATH
	PROPOSED INDUSTRIAL DRIVEWAY
	PROPOSED SHARED FOOTPATH
	PROPOSED ROAD PAVING
	EXISTING ROAD PAVING

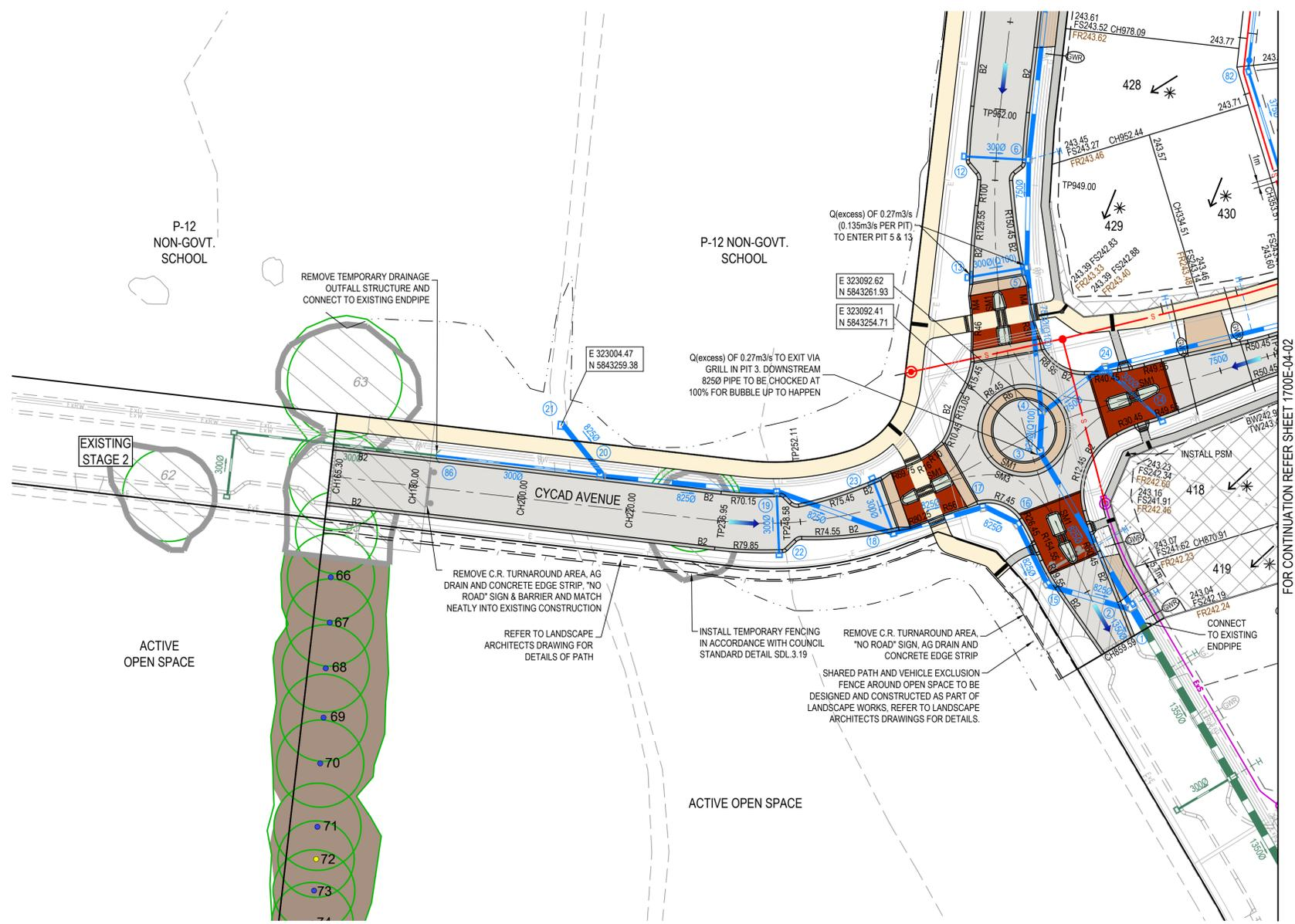
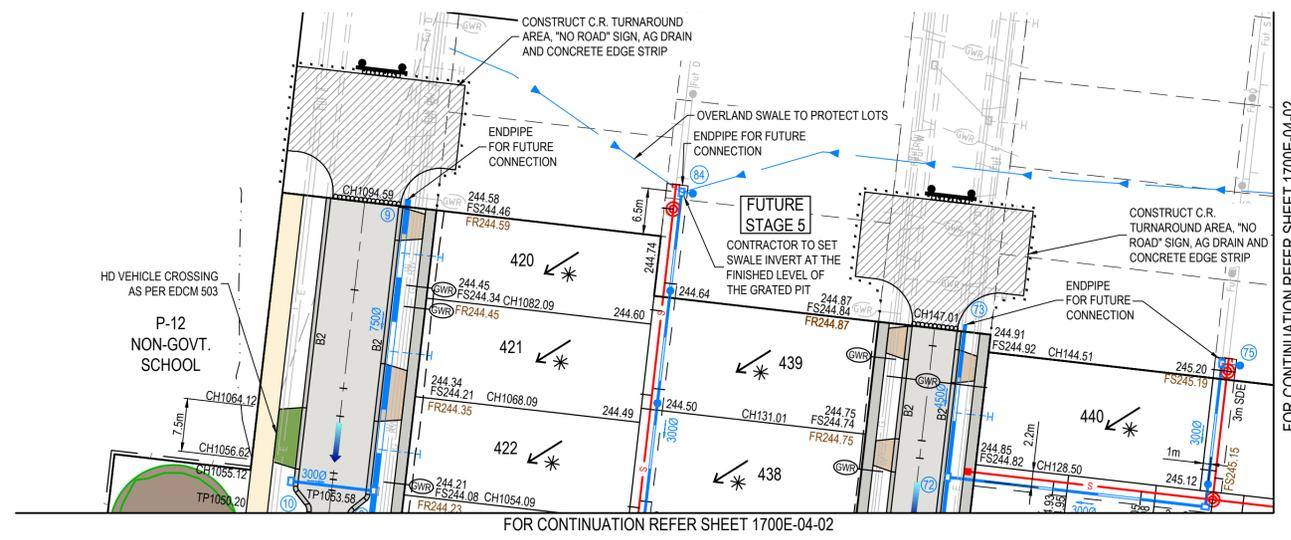

REV	DATE	AMENDMENT / REVISION DESCRIPTION	DES/DT	APPROVAL
0	05.10.18	ISSUED FOR CONSTRUCTION	PM/RB	AB

All setting out should be carried out in accordance with MPA/Council's standard drawings or as nominated on hard copy plans provided by SMEC. Any digital information supplied by this office is for information only. Any discrepancies should be discussed with the superintendent.

TITLE	NAME
DRAFTER	R.Barua
DESIGNER	P.McKay
CHECKED	Z.Gosev
AUTHORISED	A.Burrows
SMEC DRAWING REF.	1700E-04
MELBOURNE WATER REF.	388/3079

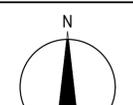

Olivine Estate - Stage 4  
Whittlesea City Council  
Road and Drainage  
Layout Plan - 2

**ISSUED FOR CONSTRUCTION**



MELWAYS REF	PROJECT / DRAWING No	SHEET No	REVISION
8 M2	1700E-04-03	03 of 45	0

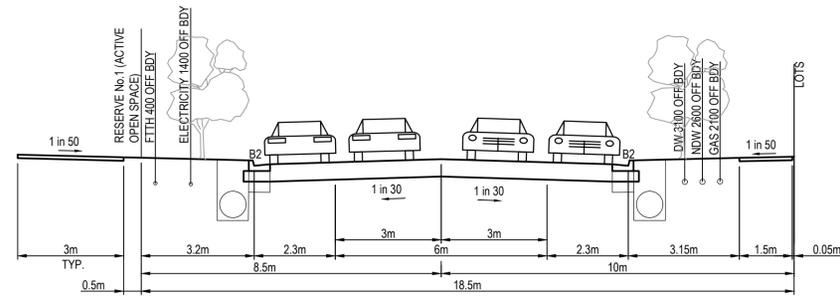

**18.5m MODIFIED ACCESS STREET 2**  
OLIVINE BOULEVARD ADJOINING LOTS & LOCAL OPEN SPACE

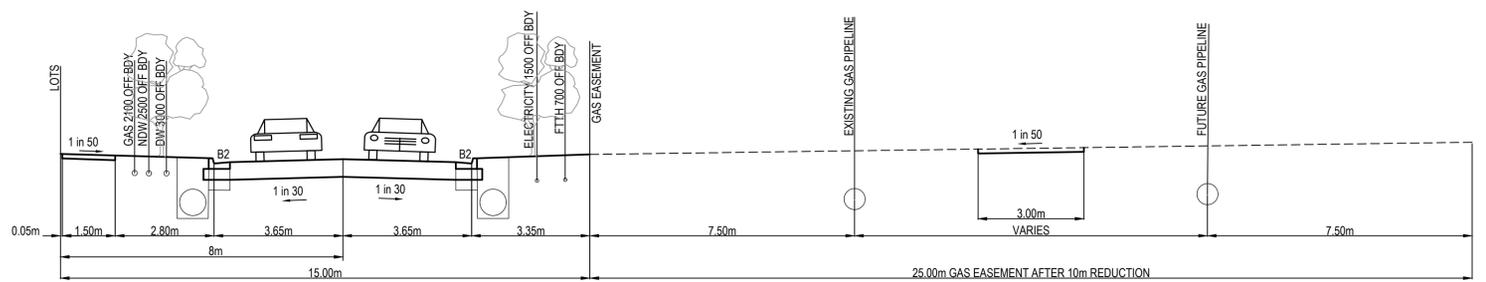

**15m MODIFIED ACCESS STREET 1 ADJACENT GAS EASEMENT**  
ORIEL ROAD & INSTITUTE DRIVE ADJACENT GAS EASEMENT

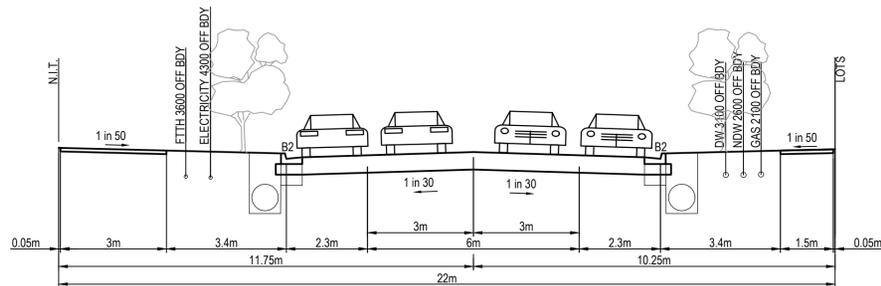

**22.0m MODIFIED ACCESS STREET 2**  
OLIVINE BOULEVARD ADJACENT LOTS AND SCHOOL

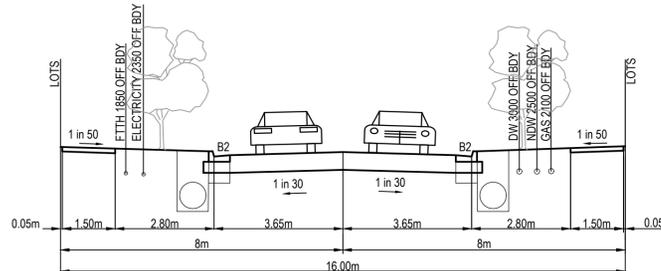

**16m ACCESS STREET**  
ACADEMY LANE, CONSERVATORY STREET, GRAMMAR,  
FACULTY & FOUNDATION AVENUES

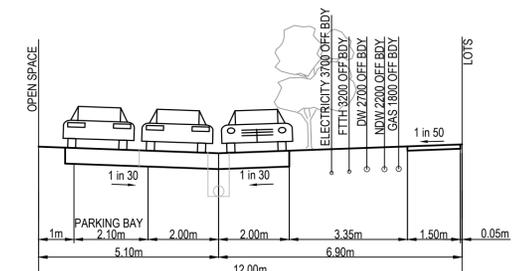

**12m ACCESS LANE**  
DEGREE LANE / HUB LANE

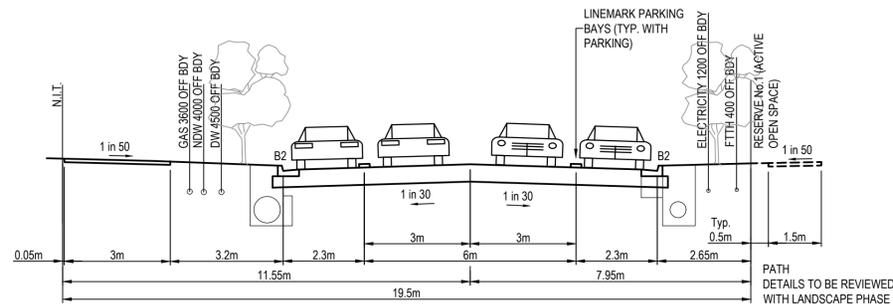

**19.5m TYPICAL CROSS SECTION**  
CYCAD AVENUE WEST OF OLIVINE BOULEVARD

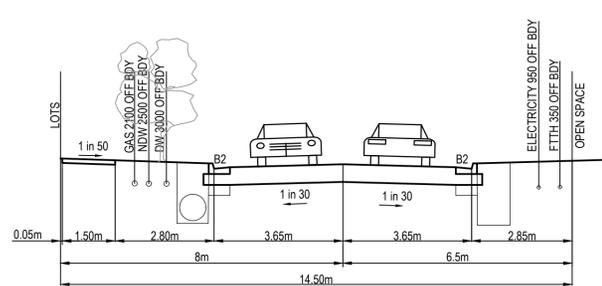

**14.5m ACCESS STREET ADJACENT OPEN SPACE**  
GRAMMAR AVENUE

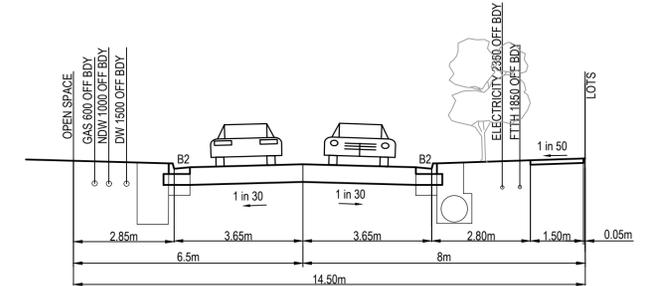

**14.5m ACCESS STREET ADJACENT OPEN SPACE**  
FACULTY AVENUE

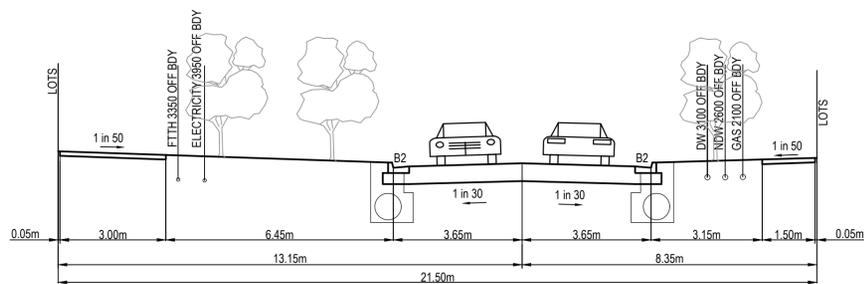

**21.5m MODIFIED ACCESS STREET 1**  
CYCAD AVENUE

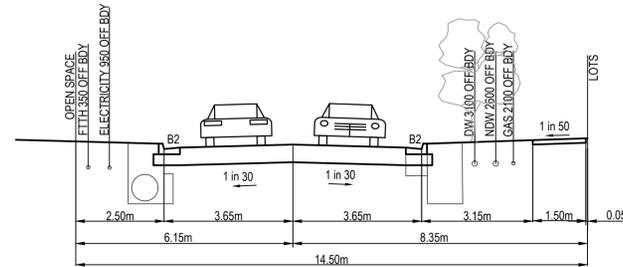

**14.5m ACCESS STREET ADJACENT OPEN SPACE**  
CYCAD AVENUE

**WARNING**  
**BEWARE OF UNDERGROUND SERVICES**  
The locations of underground services are approximate only and their exact position should be proven on site.  
No guarantee is given that all existing services are shown.  
Locate all underground services before commencement of works  
**DIAL 1100 BEFORE YOU DIG**  
www.1100.com.au

REV	DATE	AMENDMENT / REVISION DESCRIPTION	DESIGN	APPROVAL
0	05.10.18	ISSUED FOR CONSTRUCTION	PM/RB	AB

All setting out should be carried out in accordance with MPA/Council's standard drawings or as nominated on hard copy plans provided by SMEC. Any digital information supplied by this office is for information only. Any discrepancies should be discussed with the superintendent.

Quality Management ISO 9001  
 OHS Management AS/NZS 4500  
 Environmental Management ISO 14001

Global-Mark.com.au®

TITLE	NAME
DRAFTER	R.Barua
DESIGNER	P.McKay
CHECKED	Z.Gosev
AUTHORISED	A.Burrows
SMEC DRAWING REF.	1700E-04
MELBOURNE WATER REF.	388/3079

Scale H1:100, V1:50  
SCALE AS SHOWN AT A1

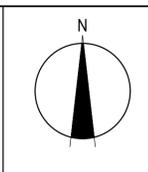

**SMEC**  
Member of the Surlana Jurong Group  
ABN 47 065 475 149  
Tower 4, Level 20, 727 Collins Street  
Docklands, VIC 3008  
Ph 03 9514 1500

**mirvac**

Olivine Estate - Stage 4 Whittlesea City Council Road and Drainage Typical Cross Sections		MELWAYS REF <b>8 M2</b>	PROJECT / DRAWING No. <b>1700E-04-04</b>	SHEET No. <b>04 of 45</b>	REVISION <b>0</b>
--	--	----------------------------	---	------------------------------	----------------------

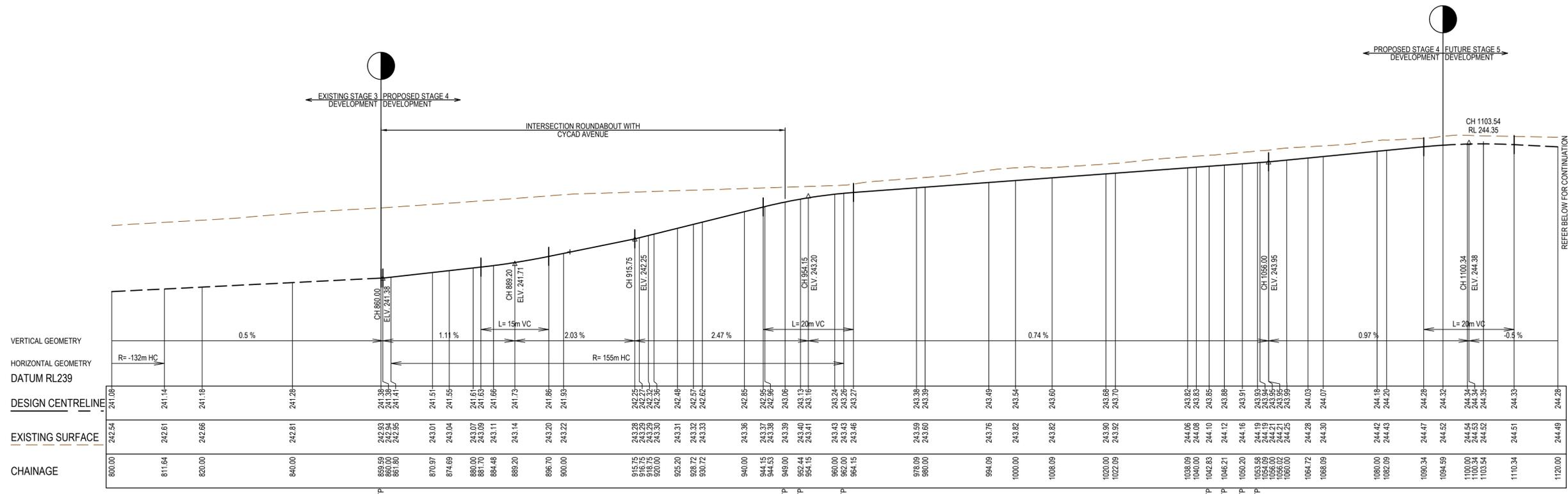

OLIVINE BOULEVARD LONGITUDINAL SECTION

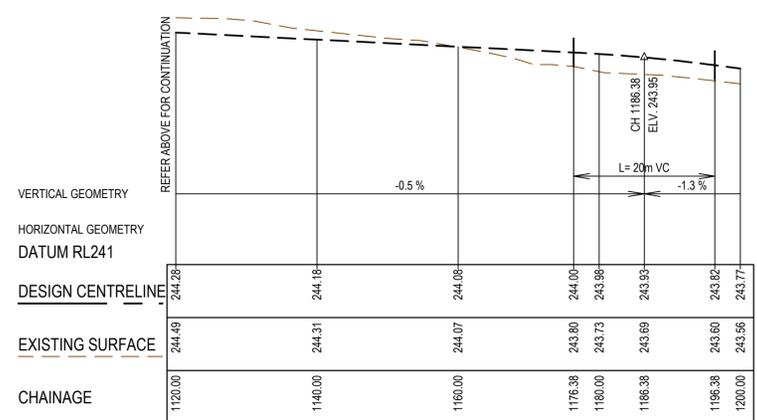

OLIVINE BOULEVARD LONGITUDINAL SECTION

DEGREE LANE DESIGN LINE

IP	CHAINAGE	X COORD	Y COORD	Z COORD	TYPE	BEARING	LENGTH	RADIUS
1	0.000	323175.514	5843384.082		IP	96°33'20.00"		
2	75.372	323250.413	5843375.475	245.774	IP		7.511	-30.000
3	84.311	323259.289	5843376.689		IP	82°12'41.61"		

ORIEL ROAD DESIGN LINE

IP	CHAINAGE	X COORD	Y COORD	Z COORD	TYPE	BEARING	LENGTH	RADIUS
1	577.687	323408.342	5843224.755	247.415	IP	6°31'31.48"		
2	618.039	323412.928	5843264.845		IP	6°31'31.48"		

CYCAD AVENUE DESIGN LINE

IP	CHAINAGE	X COORD	Y COORD	Z COORD	TYPE	BEARING	LENGTH	RADIUS
1	165.295	322962.071	5843250.096	242.057	IP	96°33'20.01"		
2	236.950	323033.257	5843241.916	241.698	TC	96°33'20.01"		
3	260.108	323057.024	5843239.185	241.583	IP		46.317	-75.000
4	283.267	323077.983	5843250.720	241.739	CT	61°10'19.29"		
5	295.184	323088.424	5843256.467	241.935	TC	61°10'19.29"		
6	303.011	323095.305	5843260.254	242.065	IP		15.653	75.000
7	310.837	323102.822	5843262.534	242.194	CT	73°07'47.80"		
8	317.434	323185.692	5843287.664	243.363	TC	73°07'47.80"		
9	405.264	323193.294	5843289.968	243.418	IP		15.659	38.350
10	413.093	323201.180	5843289.066	243.473	CT	96°31'31.48"		
11	446.316	323234.187	5843285.291	243.713	TC	96°31'31.48"		
12	453.000	323240.891	5843284.524	243.800	IP		13.369	-40.000
13	459.684	323247.475	5843285.998	243.926	CT	77°22'35.45"		
14	459.685	323247.475	5843285.998	243.926	TC	77°22'35.45"		
15	471.081	323259.029	5843288.586	244.196	IP		22.793	34.099
16	482.477	323269.701	5843283.456	244.470	CT	115°40'27.50"		
17	482.478	323269.701	5843283.456	244.470	TC	115°40'27.50"		
18	489.162	323275.782	5843280.533	244.630	IP		13.369	-40.000
19	495.846	323282.485	5843279.766	244.790	CT	96°31'31.48"		
20	634.140	323419.883	5843264.050	249.907	IP	96°31'31.48"		

CONSERVATORY ST DESIGN LINE

IP	CHAINAGE	X COORD	Y COORD	Z COORD	TYPE	BEARING	LENGTH	RADIUS
1	0.000	323282.186	5843355.511	245.448	IP	82°12'41.61"		
2	26.900	323286.838	5843359.156	245.165	TC	82°12'41.61"		
3	33.146	323295.058	5843360.007	245.404	IP		12.491	50.000
4	39.391	323301.296	5843359.293	246.643	CT	96°31'31.48"		
5	152.434	323413.606	5843346.447	251.269	TC	96°31'31.48"		
6	159.189	323422.150	5843345.470	251.535	IP		13.509	-8.600
7	165.943	323423.128	5843354.014	251.761	CT	6°31'31.48"		
8	193.341	323426.241	5843381.234	252.283	IP	6°31'31.48"		

FOUNDATION AVE DESIGN LINE

IP	CHAINAGE	X COORD	Y COORD	Z COORD	TYPE	BEARING	LENGTH	RADIUS
1	0.000	323337.272	5843355.178		IP	6°33'20.00"		
2	53.997	323343.436	5843408.822	248.684	IP	6°33'20.00"		

FACULTY AVE DESIGN LINE

IP	CHAINAGE	X COORD	Y COORD	Z COORD	TYPE	BEARING	LENGTH	RADIUS
1	0.000	323258.802	5843286.602	244.196	IP	6°31'31.48"		
2	46.052	323263.922	5843331.362	245.141	TC	6°31'31.48"		
3	51.297	323264.635	5843337.599	245.262	IP		12.491	-50.000
4	57.543	323263.785	5843343.820	245.348	CT	352°12'41.61"		
5	100.860	323257.915	5843386.737	245.661	TC	352°12'41.61"		
6	107.119	323257.062	5843392.970	245.695	IP		12.518	50.000
7	113.377	323257.780	5843399.221	245.728	CT	6°33'20.00"		
8	133.845	323260.117	5843419.555	245.839	IP	6°33'20.00"		

GRAMMAR AVE DESIGN LINE

IP	CHAINAGE	X COORD	Y COORD	Z COORD	TYPE	BEARING	LENGTH	RADIUS
1	0.000	323181.939	5843286.526	243.335	IP	329°30'57.92"		
2	36.504	323171.346	5843321.459	244.014	TC	343°07'47.80"		
3	43.965	323169.150	5843328.700	244.070	IP		14.923	36.500
4	51.427	323170.014	5843336.218	244.119	CT	6°33'20.00"		
5	147.007	323180.926	5843431.174	244.741	IP	6°33'20.00"		

OLIVINE BOULEVARD DESIGN LINE

IP	CHAINAGE	X COORD	Y COORD	Z COORD	TYPE	BEARING	LENGTH	RADIUS
1	859.529	323106.610	5843218.999	241.383	IP	329°30'57.92"		
2	861.800	323105.458	5843220.957	241.405	TC	329°30'57.92"		
3	911.901	323079.119	5843265.701	242.172	IP		100.201	155.000
4	962.002	323085.046	5843317.283	243.256	CT	6°33'20.00"		
5	1094.595	323100.184	5843449.009	244.318	IP	6°33'20.00"		

ACADEMY LANE DESIGN LINE

IP	CHAINAGE	X COORD	Y COORD	Z COORD	TYPE	BEARING	LENGTH	RADIUS
1	40.000	323225.535	5843245.666	243.676	IP	6°31'31.48"		
2	80.351	323230.120	5843285.756	243.678	IP	6°31'31.48"		

REV	DATE	AMENDMENT / REVISION DESCRIPTION	DESIGN	APPROVAL
0	05.10.18	ISSUED FOR CONSTRUCTION	PM/RB	AB

**ISSUED FOR CONSTRUCTION**

All setting out should be carried out in accordance with MPA/Council's standard drawings or as nominated on hard copy plans provided by SMEC. Any digital information supplied by this office is for information only. Any discrepancies should be discussed with the superintendent.

TITLE	NAME
DRAFTER	R.Barua
DESIGNER	P.McKay
CHECKED	Z.Gosev
AUTHORISED	A.Burrows
SMEC DRAWING REF.	1700E-04
MELBOURNE WATER REF.	388/3079

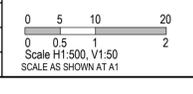

Member of the Surbana Jurong Group  
 ABN 47 065 475 149  
 Tower 4, Level 20, 727 Collins Street  
 Docklands, VIC 3008  
 Ph 03 9514 1500

Olivine Estate - Stage 4  
 Whittlesea City Council  
 Road and Drainage  
 Longitudinal Sections - 1

MELBOURNE REF	PROJECT / DRAWING No	SHEET No	REVISION
8 M2	1700E-04-05	05 of 45	0

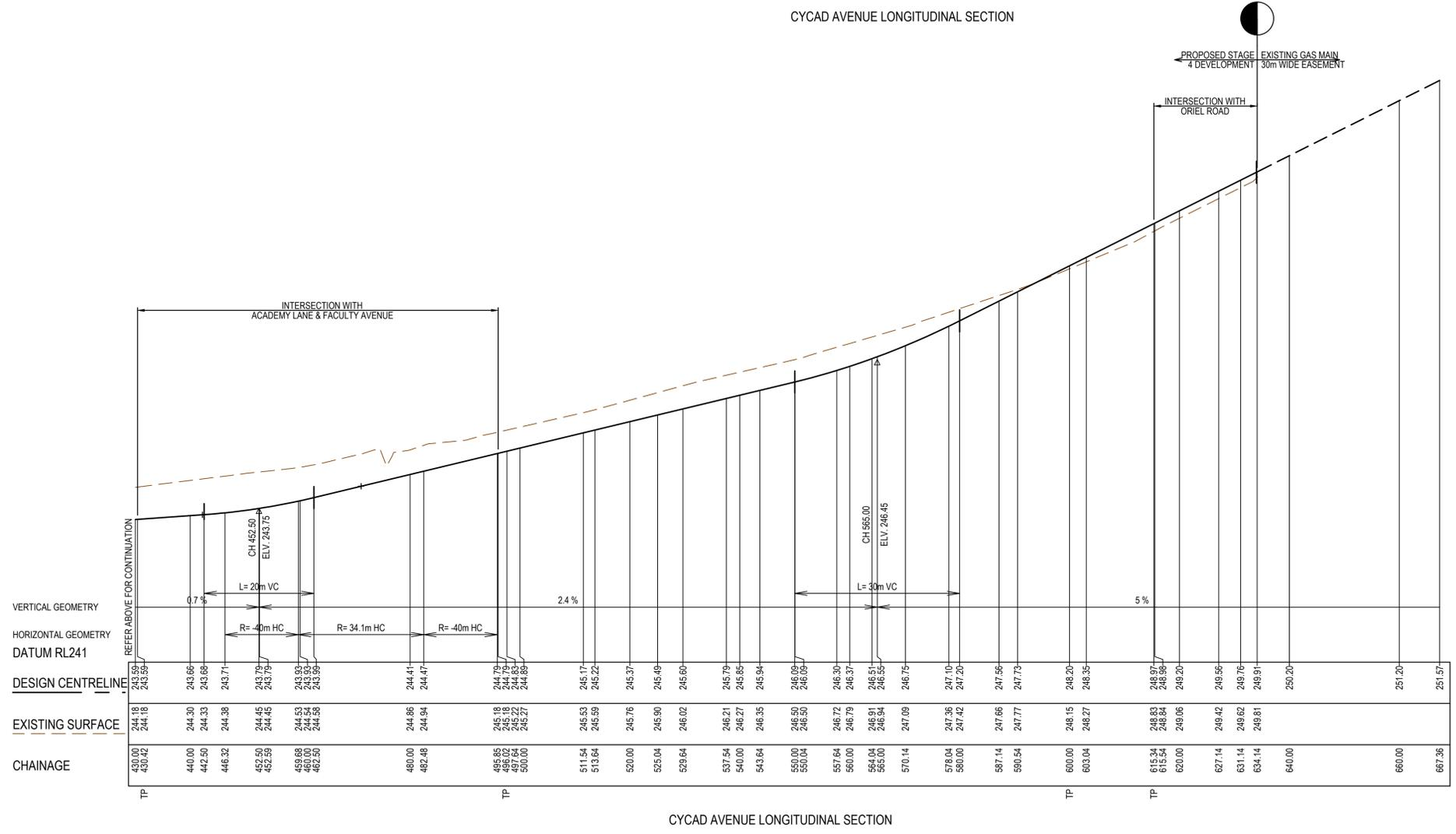
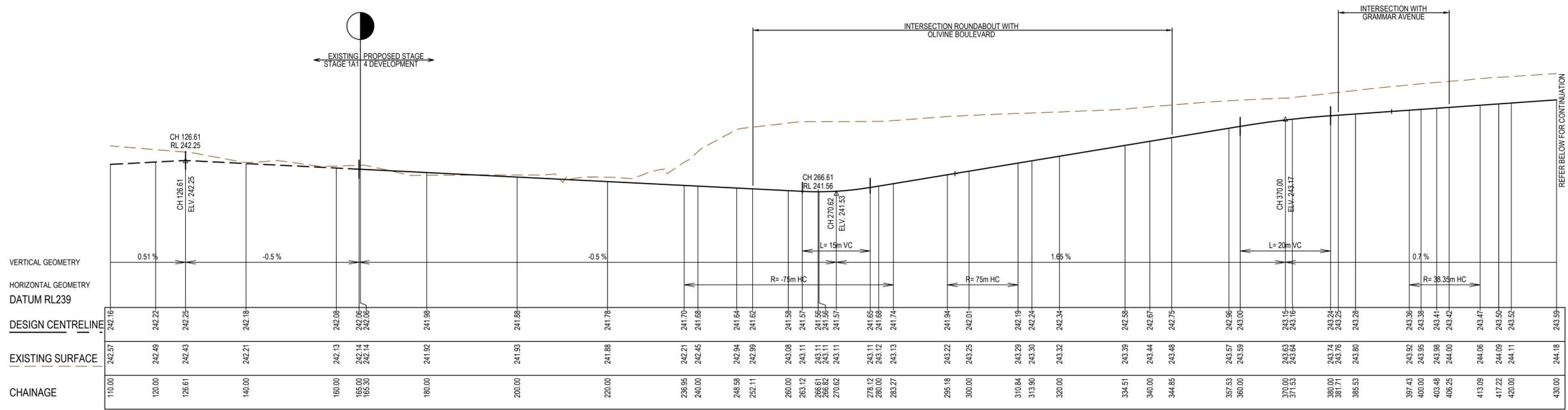

REV	DATE	AMENDMENT / REVISION DESCRIPTION	DESIGN	APPROVAL
0	05.10.18	ISSUED FOR CONSTRUCTION	PM/RB	AB

**ISSUED FOR CONSTRUCTION**

All setting out should be carried out in accordance with MPA/Council's standard drawings or as nominated on hard copy plans provided by SMEC. Any digital information supplied by this office is for information only. Any discrepancies should be discussed with the superintendent.

TITLE	NAME
DRAFTER	R.Barua
DESIGNER	P.McKay
CHECKED	Z.Gosev
AUTHORISED	A.Burrows
SMEC DRAWING REF.	1700E-04
MELBOURNE WATER REF.	388/3079

0 5 10 20  
0 0.5 1 2  
Scale H1:500, V1:50  
SCALE AS SHOWN AT 1

Member of the **Surbana Jurong Group**  
 ABN 47 065 475 149  
 Tower 4, Level 20, 727 Collins Street  
 Docklands, VIC 3008  
 Ph 03 9514 1500

Olivine Estate - Stage 4  
 Whittlesea City Council  
 Road and Drainage  
 Longitudinal Sections - 2

MELWAYS REF <b>8 M2</b>	PROJECT / DRAWING No. <b>1700E-04-06</b>	SHEET No. <b>06 of 45</b>	REVISION <b>0</b>
----------------------------	---	------------------------------	----------------------

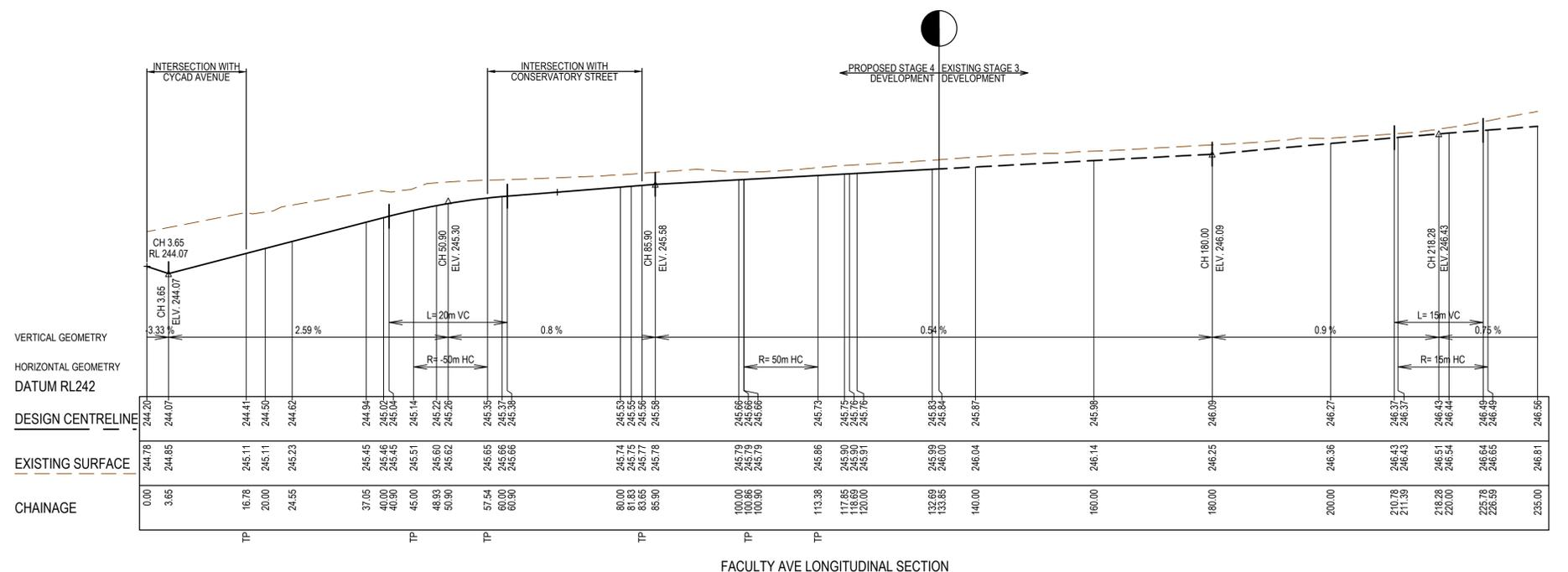
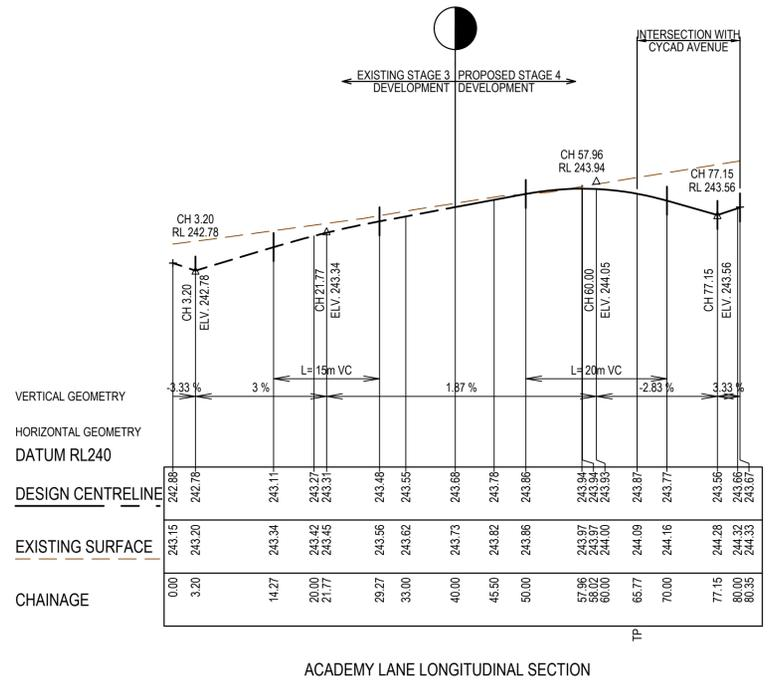
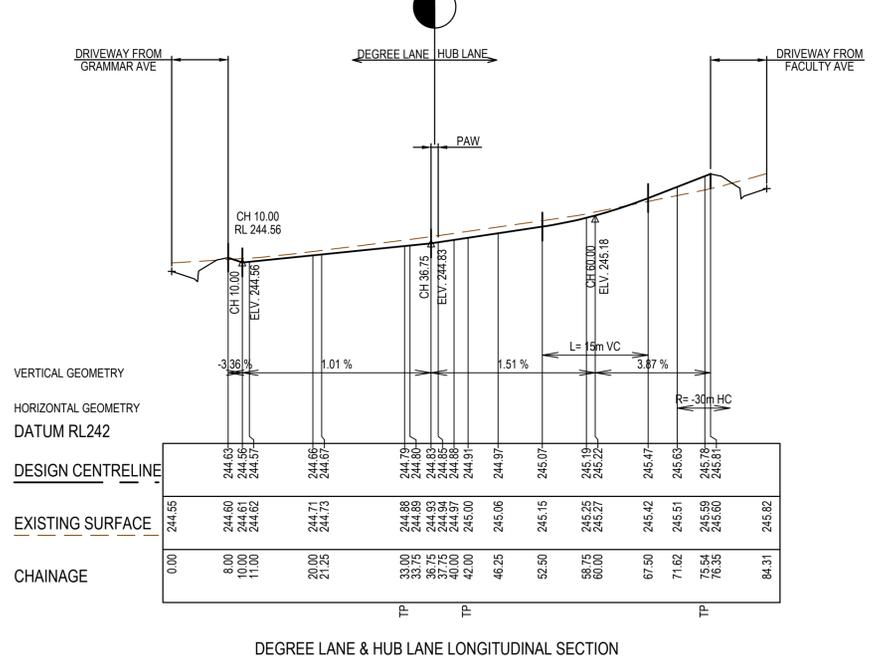
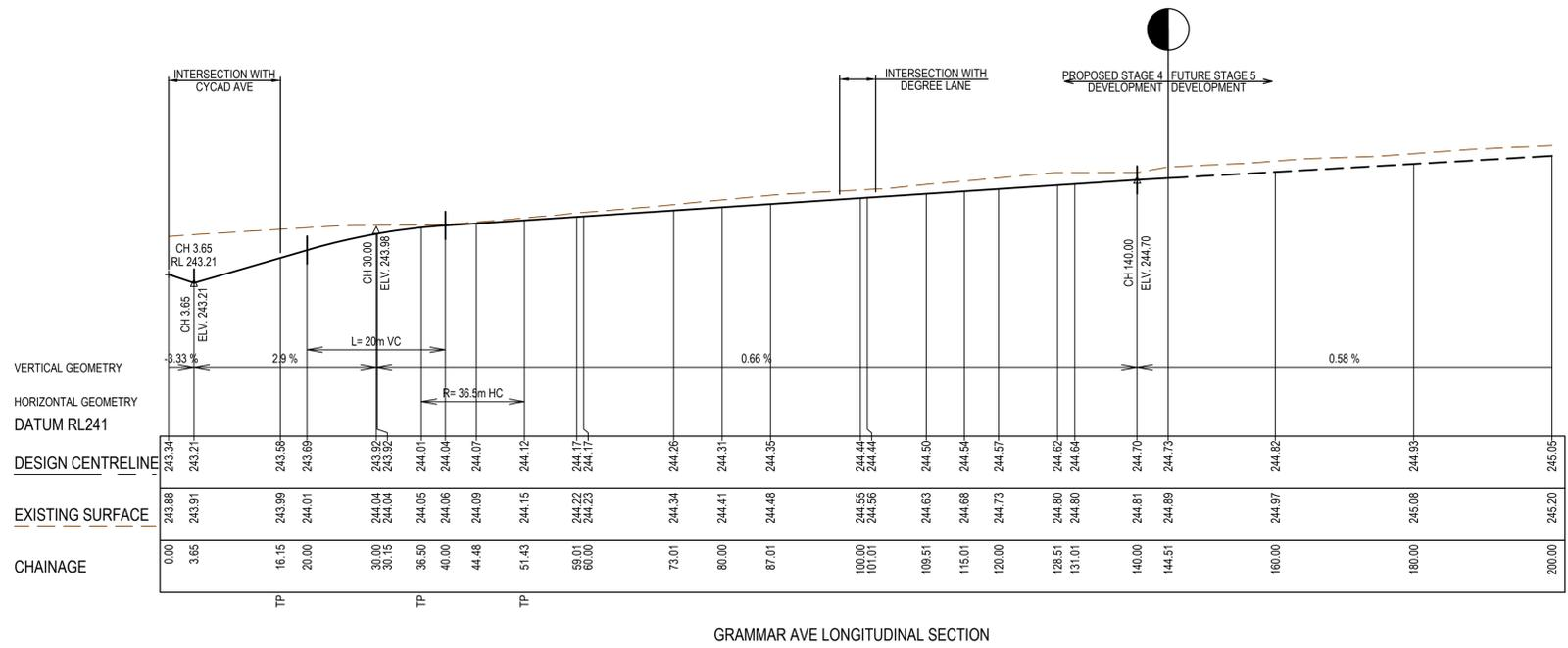

REV	DATE	AMENDMENT / REVISION DESCRIPTION	DESIGN	APPROVAL
0	05.10.18	ISSUED FOR CONSTRUCTION	PM/RB	AB

**ISSUED FOR CONSTRUCTION**

All setting out should be carried out in accordance with MPA/Council's standard drawings or as nominated on hard copy plans provided by SMEC. Any digital information supplied by this office is for information only. Any discrepancies should be discussed with the superintendent.		TITLE	NAME
Quality Management ISO 9001	Site Management AS/NZS 1800	DRAFTER	R.Barua
Environmental Management ISO 14001	Global-Mark.com.au®	DESIGNER	P.McKay
		CHECKED	Z.Gosev
		AUTHORISED	A.Burrows
		SMEC DRAWING REF.	1700E-04
		MELBOURNE WATER REF.	388/3079

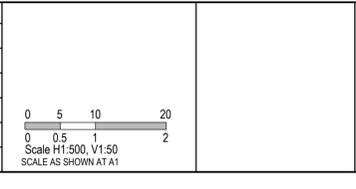

**SMEC**  
Member of the Surbana Jurong Group  
ABN 47 065 475 149  
Tower 4, Level 20, 727 Collins Street  
Docklands, VIC 3008  
Ph 03 9514 1500

**mirvac**

Olivine Estate - Stage 4 Whittlesea City Council Road and Drainage Longitudinal Sections - 3		MELWAYS REF <b>8 M2</b>	PROJECT / DRAWING No <b>1700E-04-07</b>	SHEET No <b>07 of 45</b>	REVISION <b>0</b>
---	--	----------------------------	--	-----------------------------	----------------------

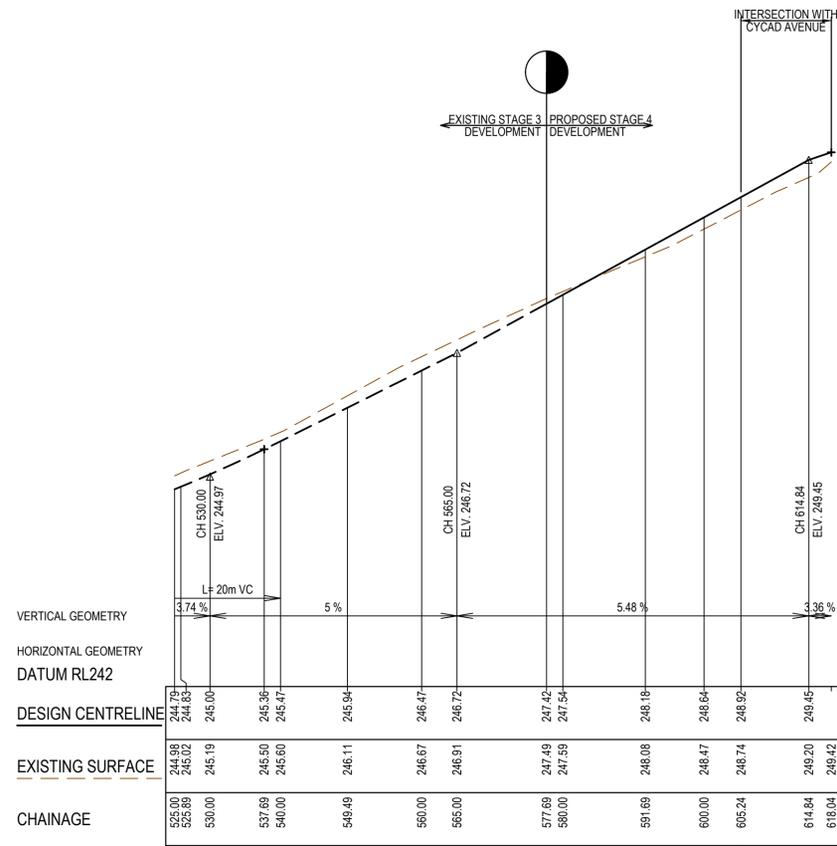

Oriel Road Longitudinal Section

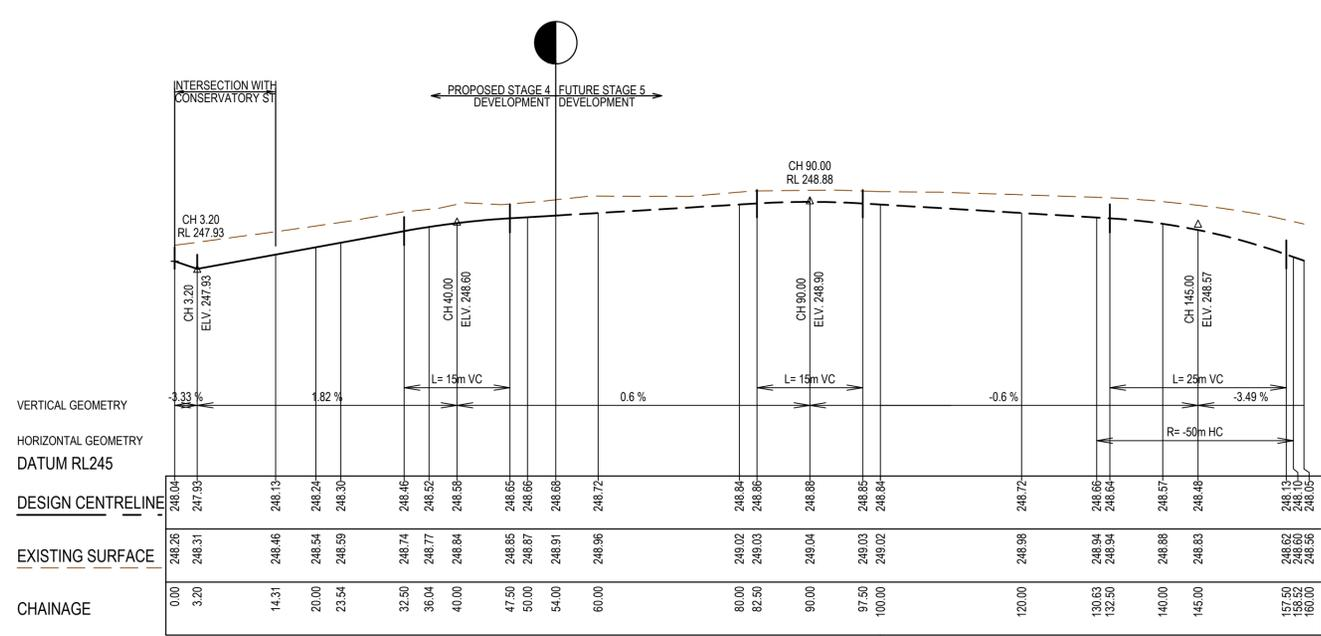

Foundation Ave Longitudinal Section

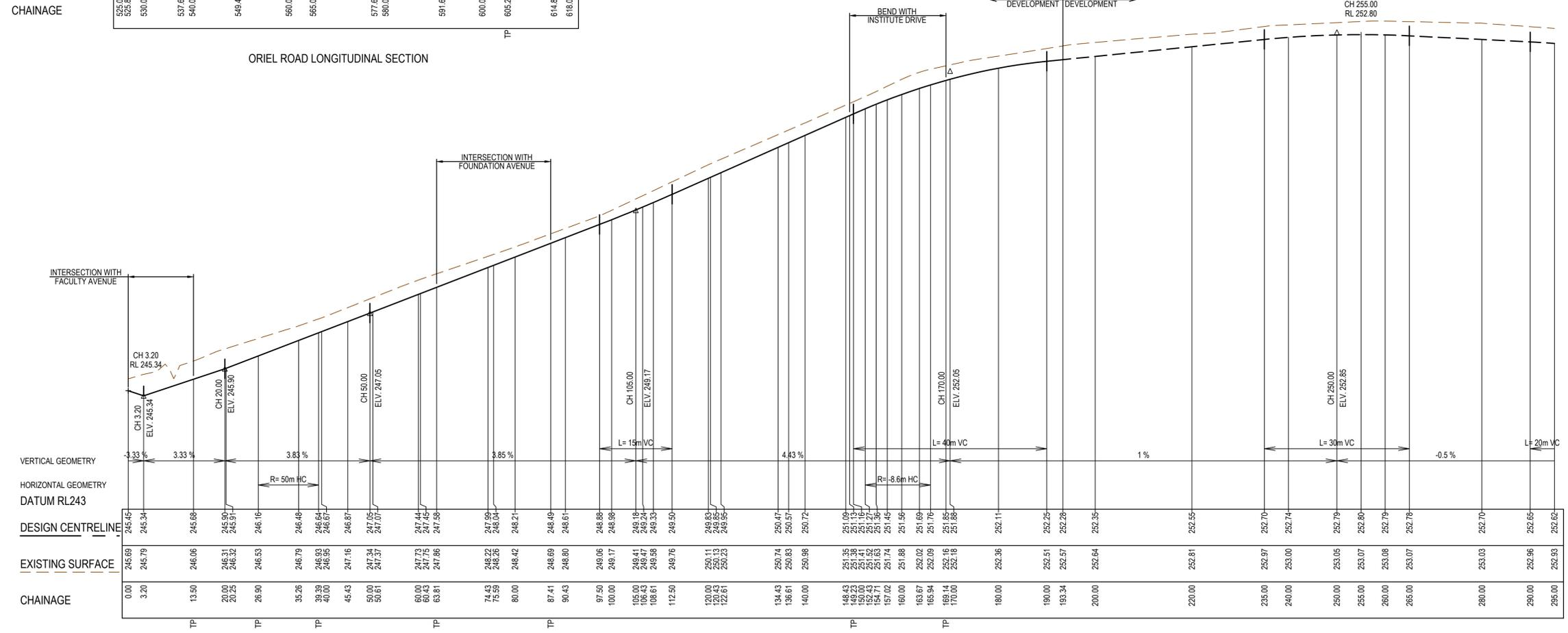

Conservatory St Longitudinal Section

REV	DATE	AMENDMENT / REVISION DESCRIPTION	DESIGN	APPROVAL
0	05.10.18	ISSUED FOR CONSTRUCTION	PM/RB	AB

All setting out should be carried out in accordance with MPA/Council's standard drawings or as nominated on hard copy plans provided by SMEC. Any digital information supplied by this office is for information only. Any discrepancies should be discussed with the superintendent.

TITLE	NAME
DRAFTER	R.Barua
DESIGNER	P.McKay
CHECKED	Z.Gosev
AUTHORISED	A.Burrows
SMEC DRAWING REF.	1700E-04
MELBOURNE WATER REF.	388/3079



Olivine Estate - Stage 4  
Whittlesea City Council  
Road and Drainage  
Longitudinal Sections - 4

**ISSUED FOR CONSTRUCTION**

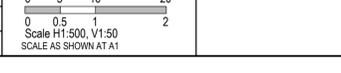

Tower 4, Level 20, 727 Collins Street  
Docklands, VIC 3008  
Ph 03 9514 1500

MELWAYS REF	PROJECT / DRAWING No	SHEET No	REVISION
8 M2	1700E-04-08	08 of 45	0



STRUCTURAL FILL REQUIRED UNDER PAVEMENT AND FOOTPATHS WHERE CONSTRUCTED ABOVE EXISTING SURFACE

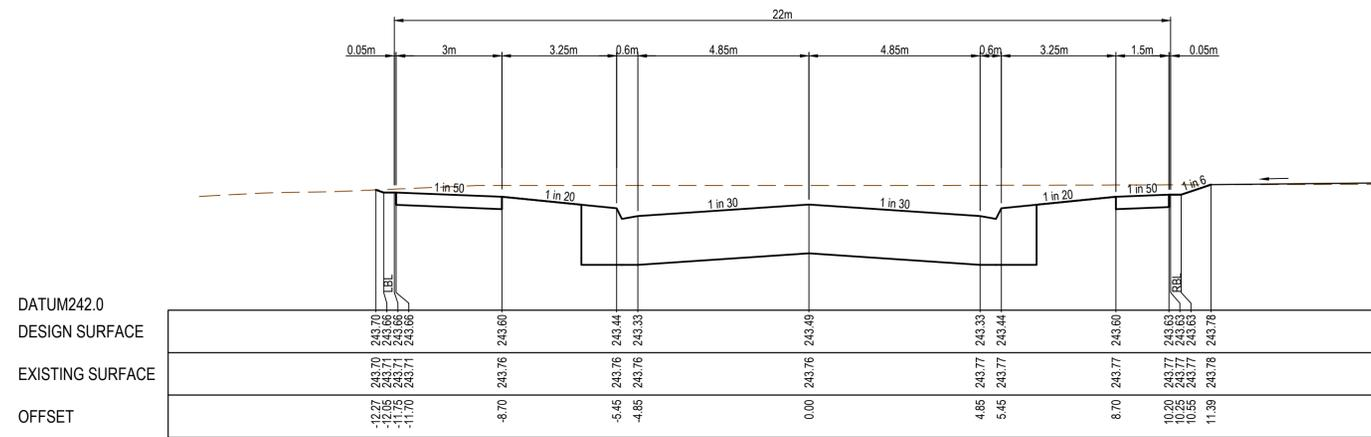

CH 994.09

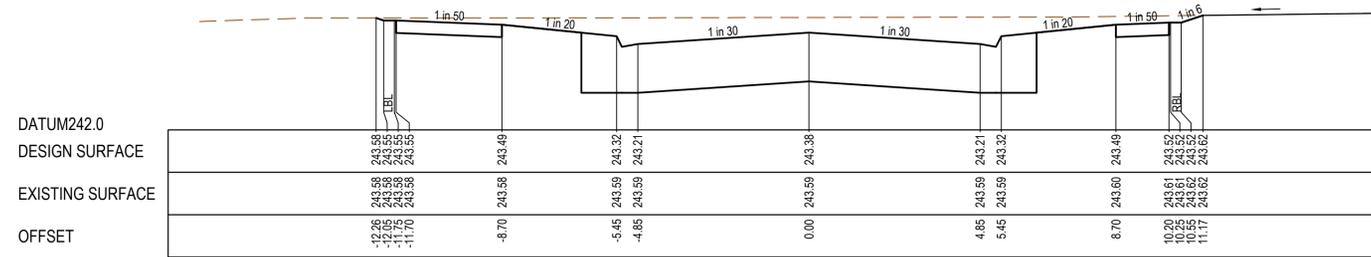

CH 978.09

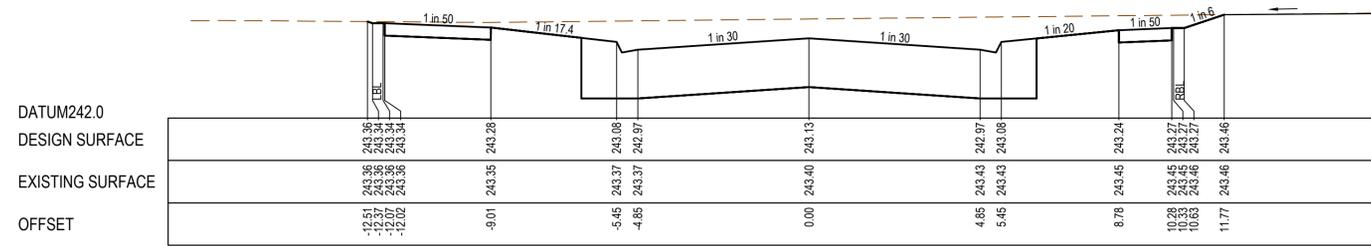

TP 952.44

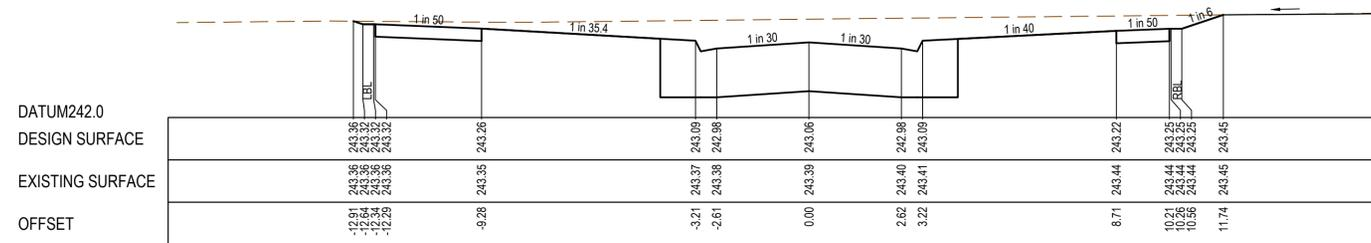

TP 949.00

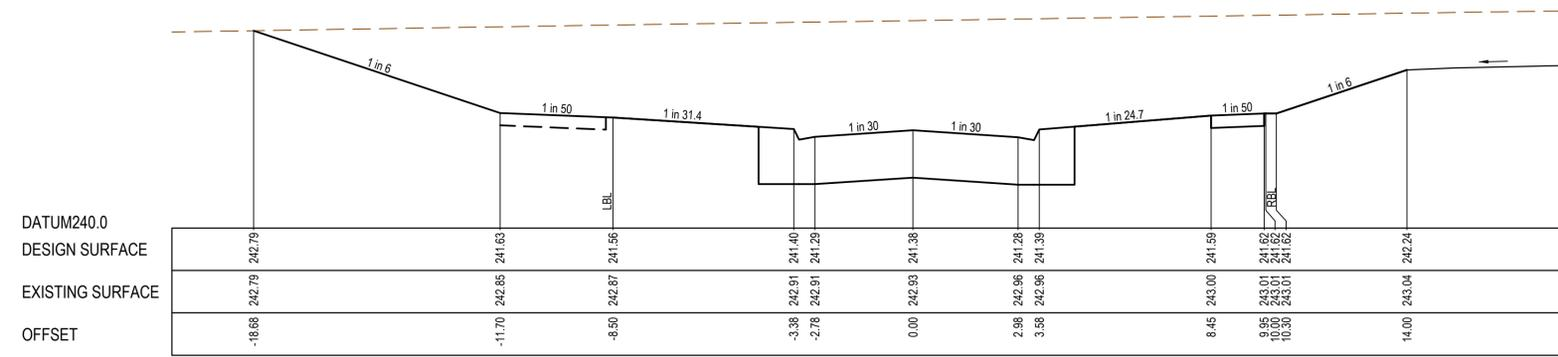

CH 859.59

REV	DATE	AMENDMENT / REVISION DESCRIPTION	DESIGN	APPROVAL
0	05.10.18	ISSUED FOR CONSTRUCTION	PM/RB	AB

All setting out should be carried out in accordance with MPA/Council's standard drawings or as nominated on hard copy plans provided by SMEC. Any digital information supplied by this office is for information only. Any discrepancies should be discussed with the superintendent.

TITLE	NAME
DRAFTER	R.Barua
DESIGNER	P.McKay
CHECKED	Z.Gosev
AUTHORISED	A.Burrows
SMEC DRAWING REF.	1700E-04
MELBOURNE WATER REF.	388/3079



Olivine Estate - Stage 4  
Whittlesea City Council  
Road and Drainage  
Cross Sections: Olivine Boulevard  
Ch 859.59 - Ch 994.09

MELWAYS REF	PROJECT / DRAWING No	SHEET No	REVISION
8 M2	1700E-04-09	09 of 45	0

STRUCTURAL FILL REQUIRED UNDER PAVEMENT AND FOOTPATHS WHERE CONSTRUCTED ABOVE EXISTING SURFACE

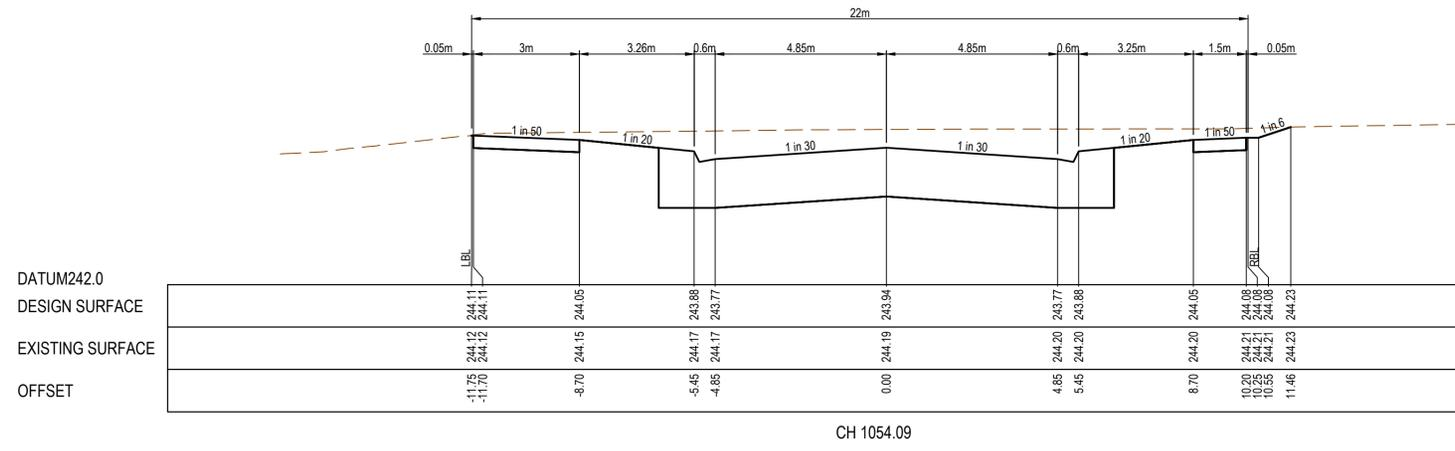

CH 1054.09

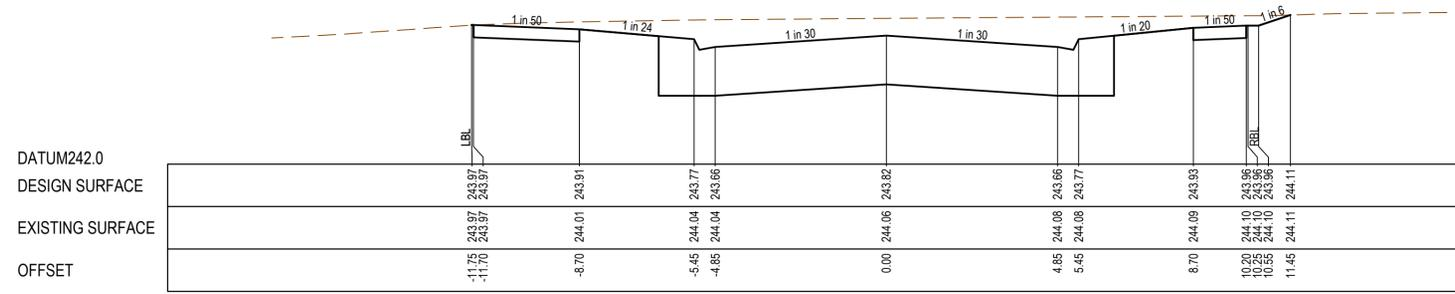

CH 1038.09

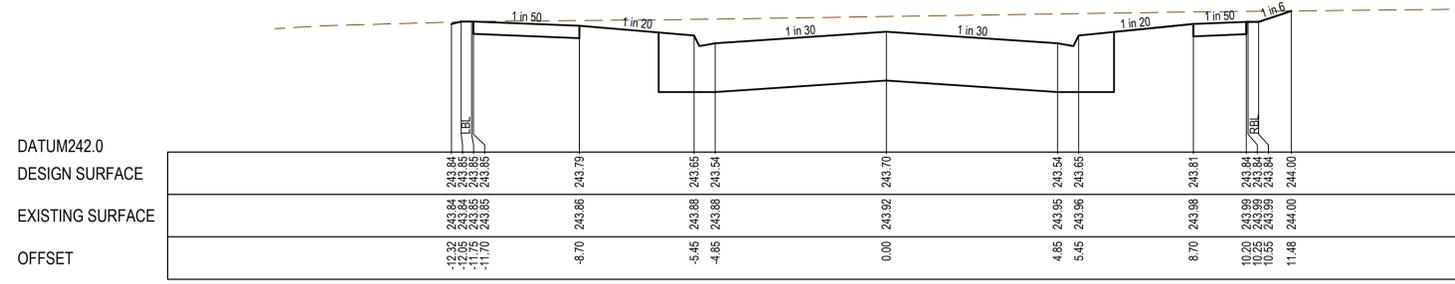

CH 1022.09

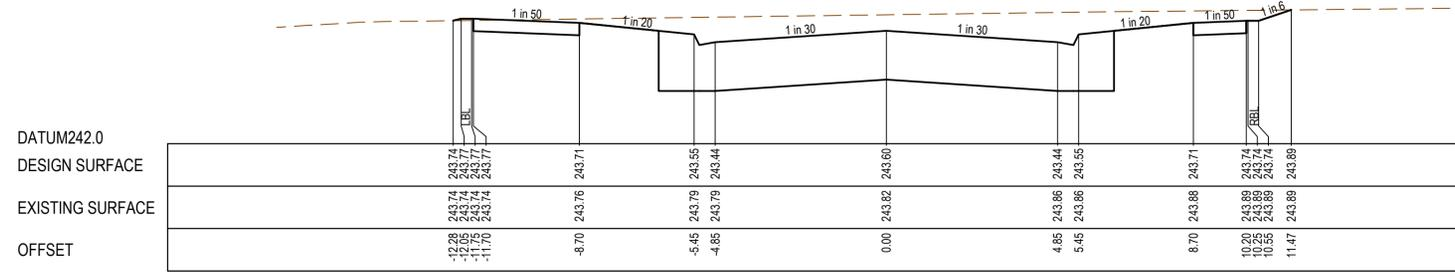

CH 1008.09

REV	DATE	AMENDMENT / REVISION DESCRIPTION	DESIGN	APPROVAL
0	05.10.18	ISSUED FOR CONSTRUCTION	PM/RB	AB

All setting out should be carried out in accordance with MPA/Council's standard drawings or as nominated on hard copy plans provided by SMEC. Any digital information supplied by this office is for information only. Any discrepancies should be discussed with the superintendent.



TITLE	NAME
DRAFTER	R.Barua
DESIGNER	P.McKay
CHECKED	Z.Gosev
AUTHORISED	A.Burrows
SMEC DRAWING REF.	1700E-04
MELBOURNE WATER REF.	388/3079

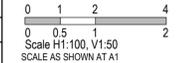

Olivine Estate - Stage 4  
Whittlesea City Council  
Road and Drainage  
Cross Sections: Olivine Boulevard  
Ch 1008.09 - Ch 1054.09

MELBOURNE REF	PROJECT / DRAWING No	SHEET No	REVISION
8 M2	1700E-04-10	10 of 45	0















STRUCTURAL FILL REQUIRED UNDER PAVEMENT AND FOOTPATHS WHERE CONSTRUCTED ABOVE EXISTING SURFACE

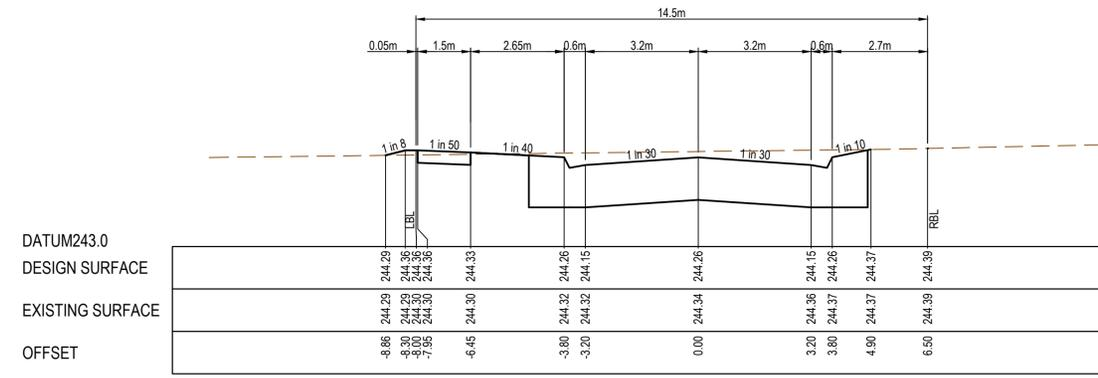

CH 73.01

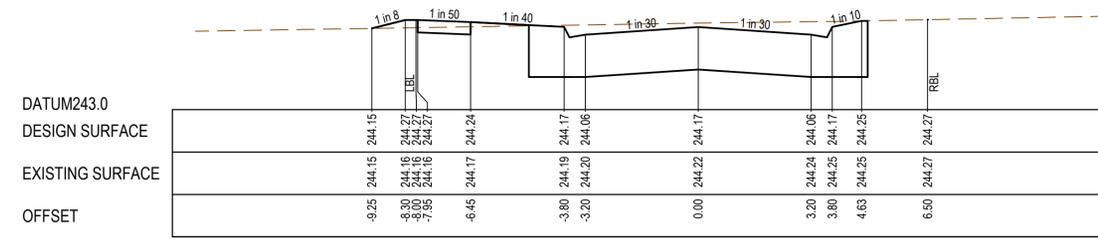

CH 59.01

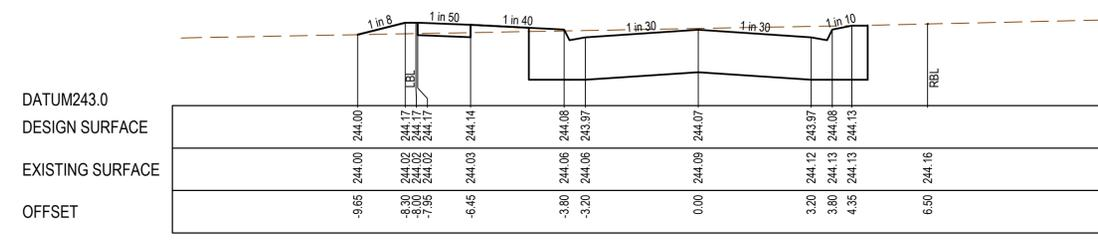

CH 44.48

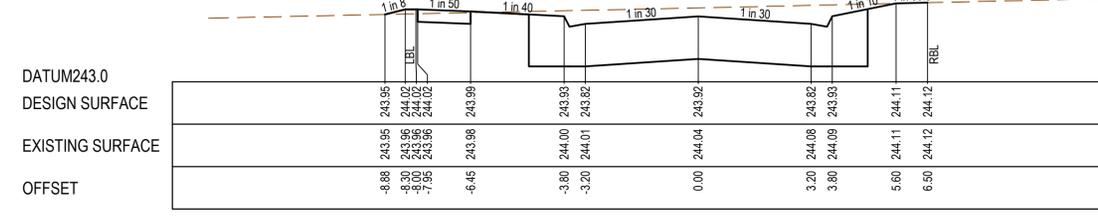

CH 30.15

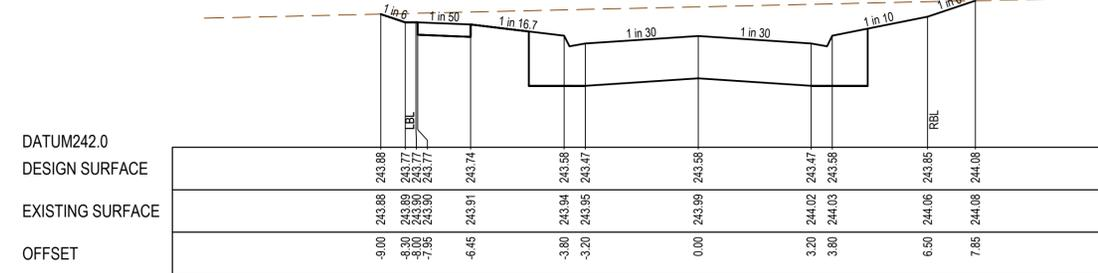

TP 16.15

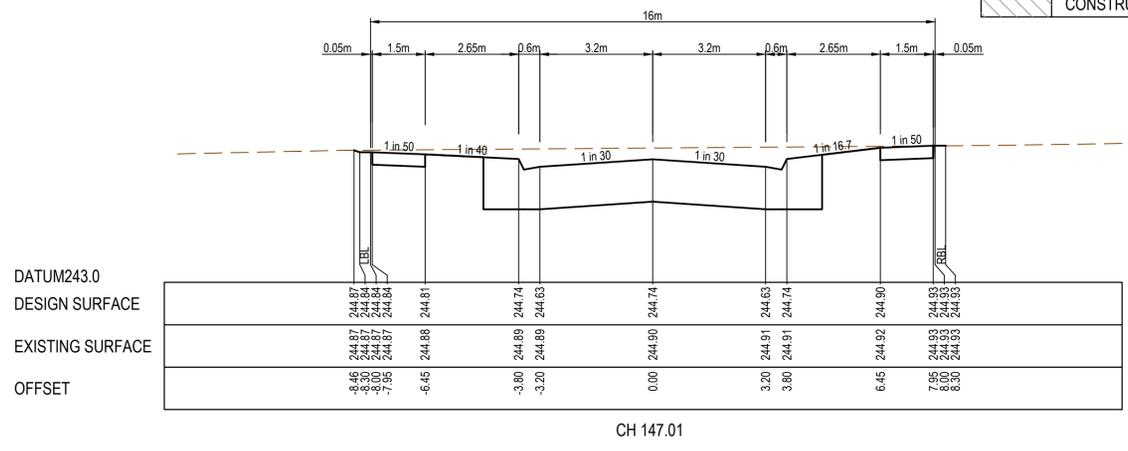

CH 147.01

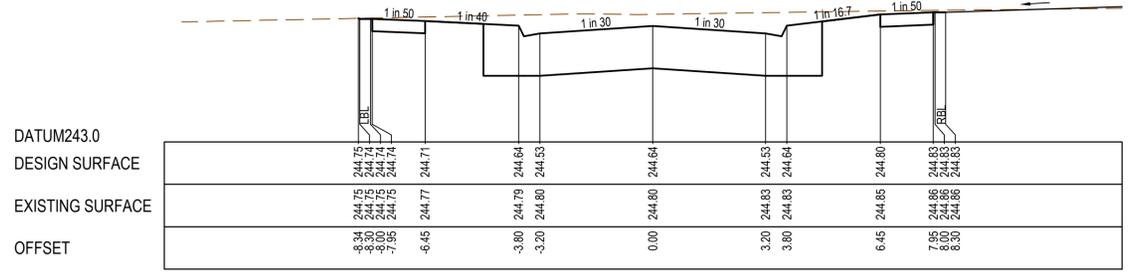

CH 131.01

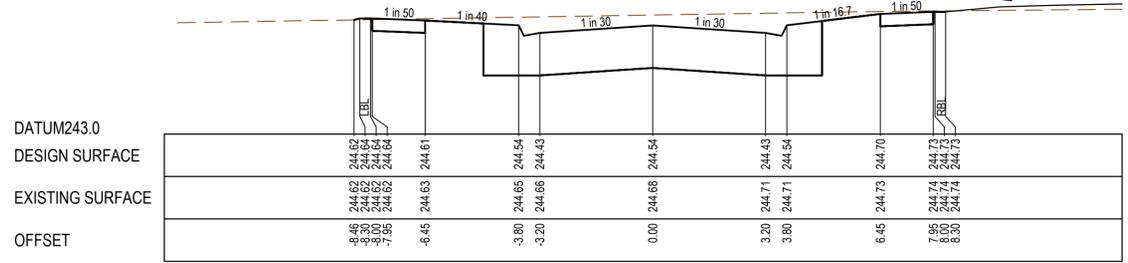

CH 115.01

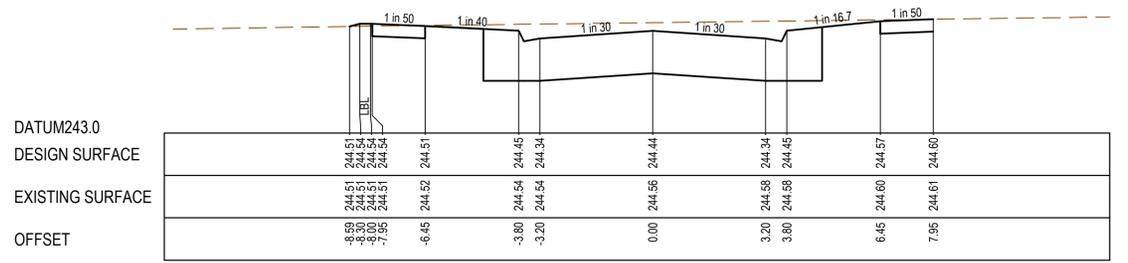

CH 101.01

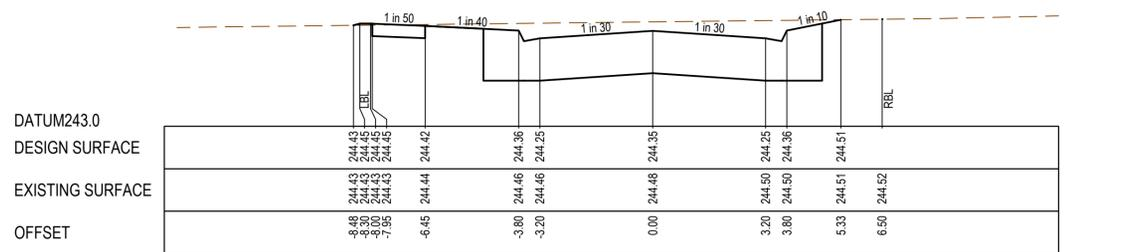

CH 87.01

REV	DATE	AMENDMENT / REVISION DESCRIPTION	DESIGN	APPROVAL
0	05.10.18	ISSUED FOR CONSTRUCTION	PM/RB	AB

**ISSUED FOR CONSTRUCTION**

<p>All setting out should be carried out in accordance with MPA/Council's standard drawings or as nominated on hard copy plans provided by SMEC. Any digital information supplied by this office is for information only. Any discrepancies should be discussed with the superintendent.</p> <p>Quality Management ISO 9001          OHS Management AS/NZS 1880          Environmental Management ISO 14001</p>	<p>TITLE</p> <p>DRAFTER: R.Barua</p> <p>DESIGNER: P.McKay</p> <p>CHECKED: Z.Gosev</p> <p>AUTHORISED: A.Burrows</p> <p>SMEC DRAWING REF: 1700E-04</p> <p>MELBOURNE WATER REF: 388/3079</p>	<p>NAME</p> <p>R.Barua</p> <p>P.McKay</p> <p>Z.Gosev</p> <p>A.Burrows</p>
---	---	---

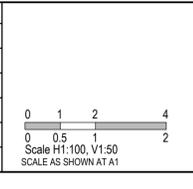

**SMEC**  
 Member of the Surbana Jurong Group  
 ABN 47 065 475 149  
 Tower 4, Level 20, 727 Collins Street  
 Docklands, VIC 3008  
 Ph 03 9514 1500

**mirvac**

<p>Olivine Estate - Stage 4          Whittlesea City Council          Road and Drainage          Cross Sections: Grammar Avenue</p>	<p>MELWAYS REF: 8 M2</p>	<p>PROJECT / DRAWING No:          1700E-04-17</p>	<p>SHEET No:          17 of 45</p>	<p>REVISION:          0</p>
---	--------------------------	---	--	---------------------------------

STRUCTURAL FILL REQUIRED UNDER PAVEMENT AND FOOTPATHS WHERE CONSTRUCTED ABOVE EXISTING SURFACE

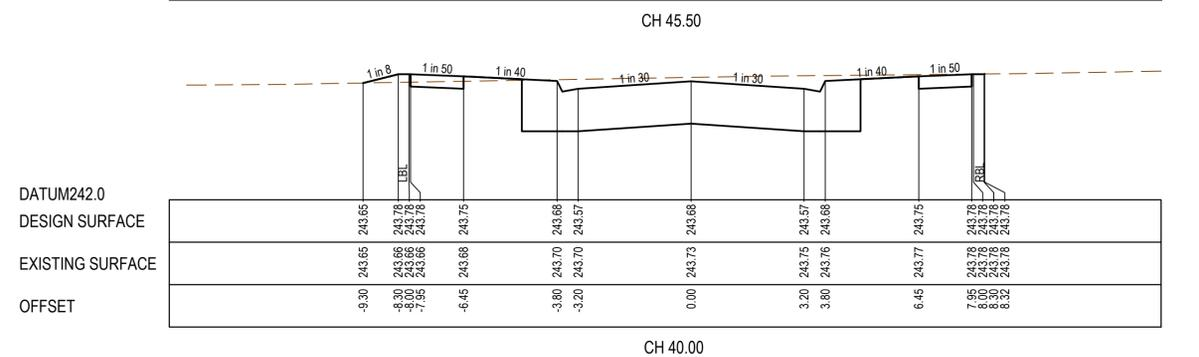
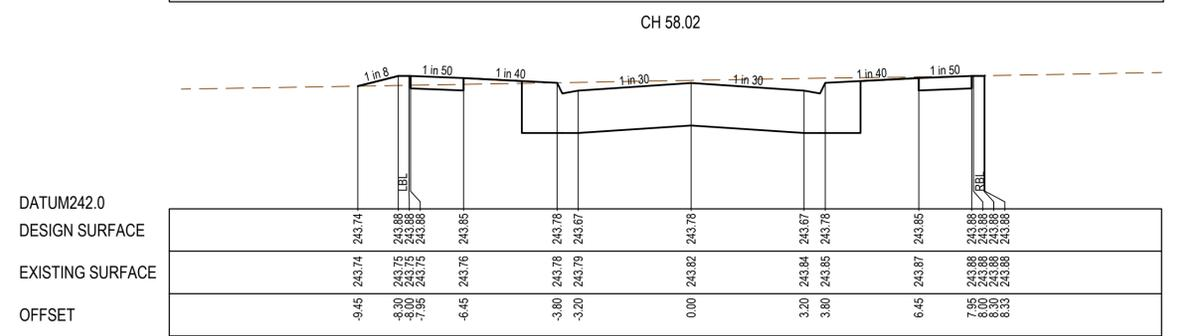
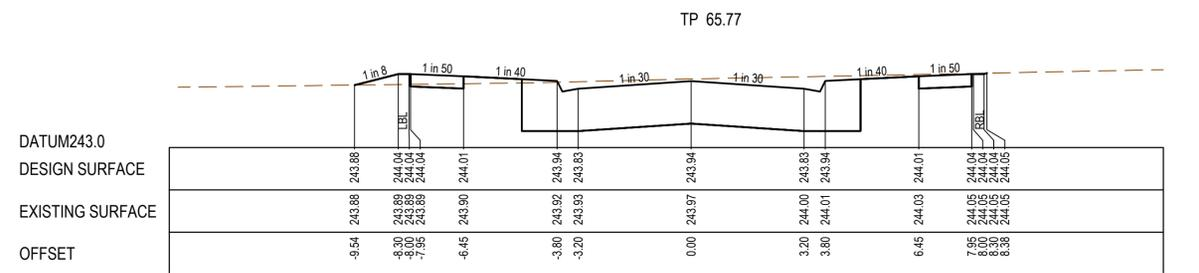
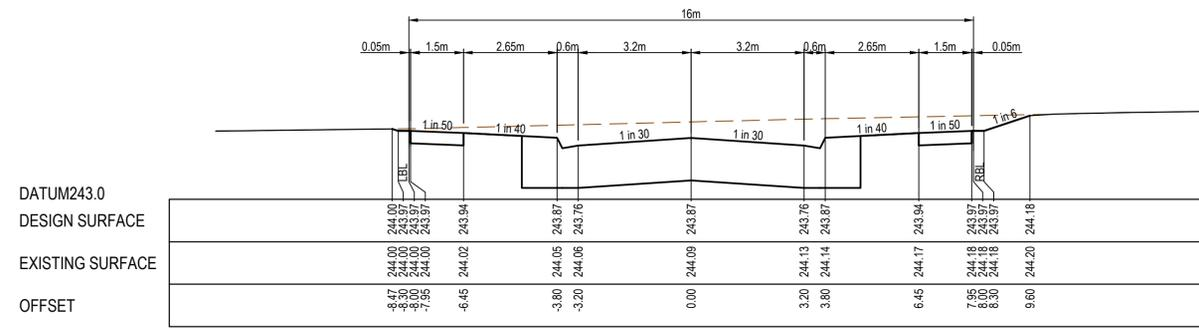

ACADEMY LANE

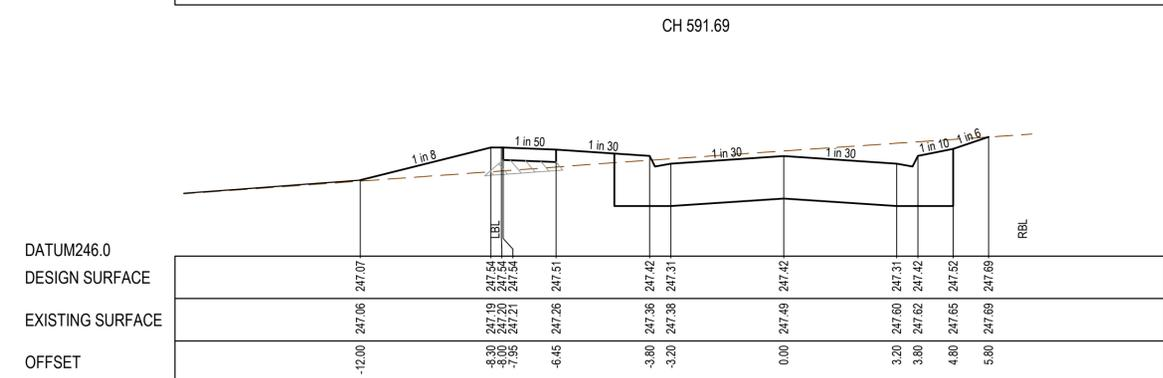
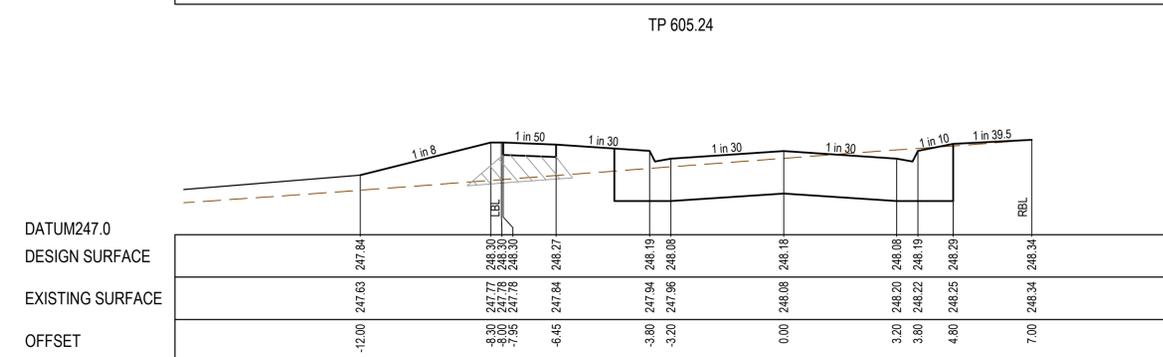
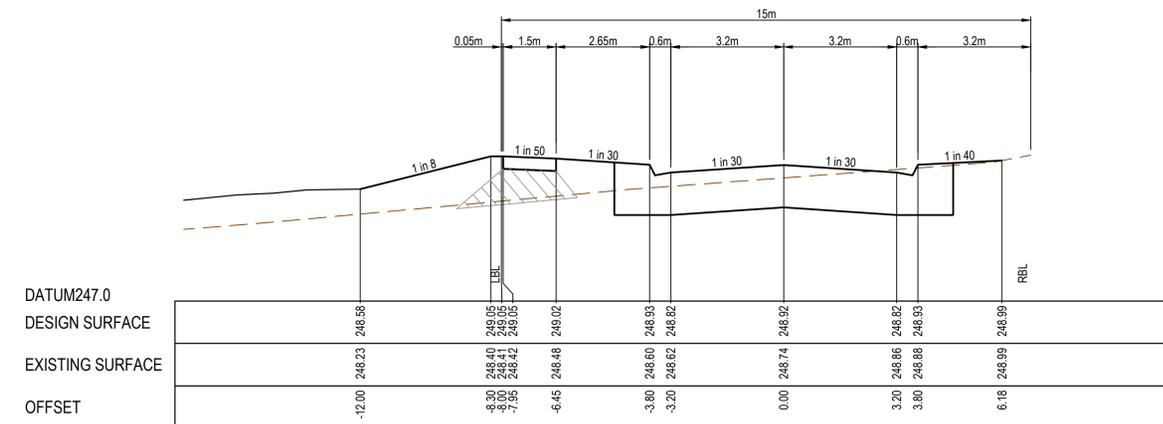

Oriel Road

REV	DATE	AMENDMENT / REVISION DESCRIPTION	DESIGN	APPROVAL
0	05.10.18	ISSUED FOR CONSTRUCTION	PM/RB	AB

All setting out should be carried out in accordance with MPA/Council's standard drawings or as nominated on hard copy plans provided by SMEC. Any digital information supplied by this office is for information only. Any discrepancies should be discussed with the superintendent.

Quality Management ISO 9001  
 OHS Management AS/NZS 1881  
 Environmental Management ISO 14001

TITLE	NAME
DRAFTER	R.Barua
DESIGNER	P.McKay
CHECKED	Z.Gosev
AUTHORISED	A.Burrows
SMEC DRAWING REF.	1700E-04
MELBOURNE WATER REF.	388/3079

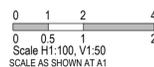

Olivine Estate - Stage 4  
 Whittlesea City Council  
 Road and Drainage  
 Cross Sections: Academy Lane & Oriel Road

MELBOURNE REF	PROJECT / DRAWING No	SHEET No	REVISION
8 M2	1700E-04-18	18 of 45	0

STRUCTURAL FILL REQUIRED UNDER PAVEMENT AND FOOTPATHS WHERE CONSTRUCTED ABOVE EXISTING SURFACE

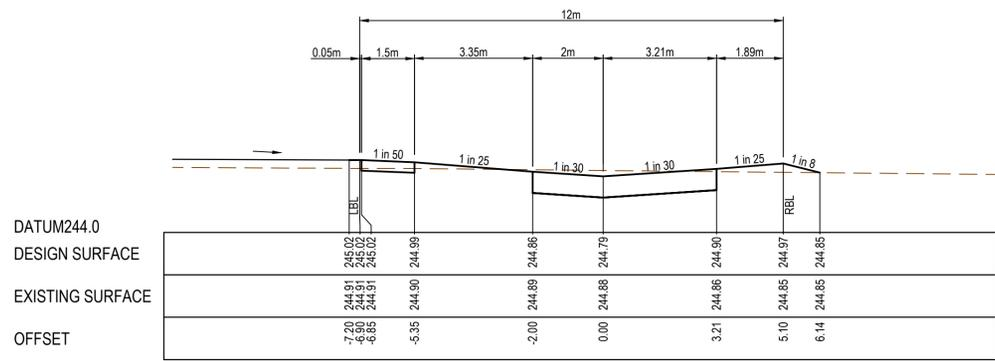

CH 33.00

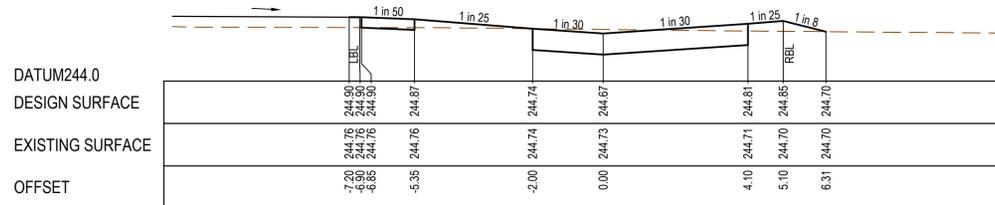

CH 21.25

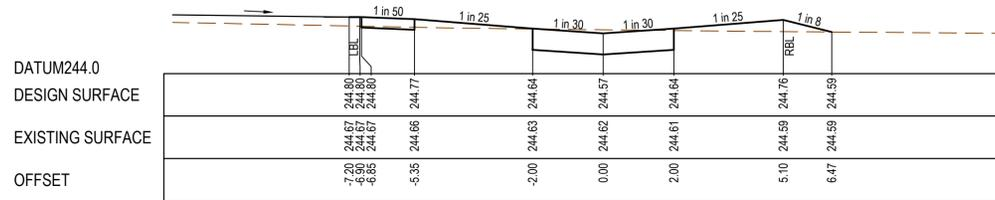

CH 11.00

DEGREE LANE

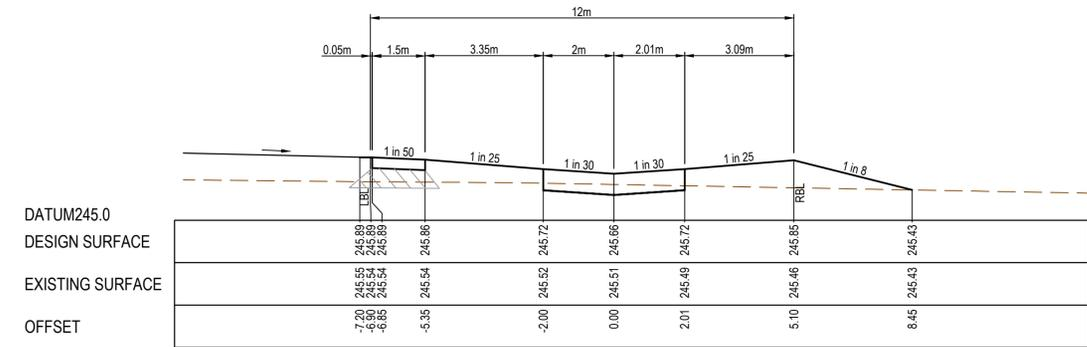

CH 71.61

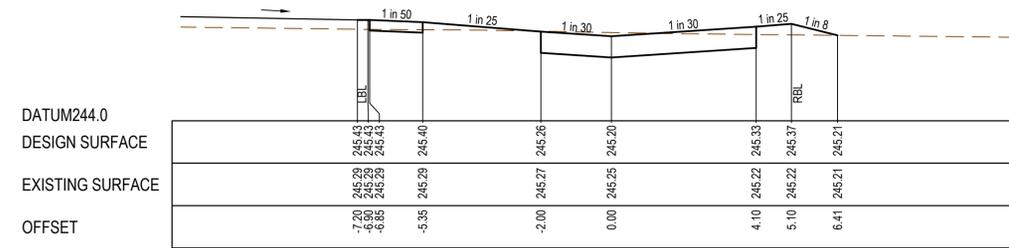

CH 58.75

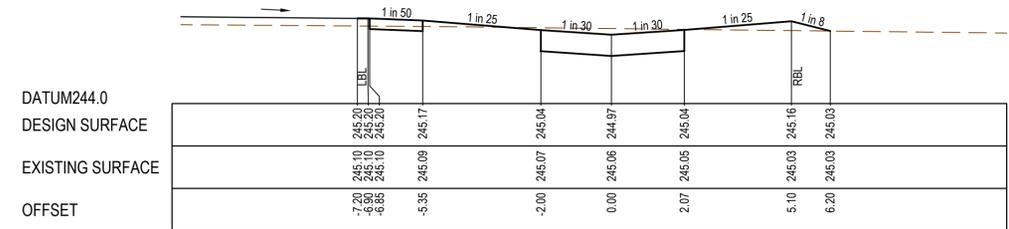

CH 46.25

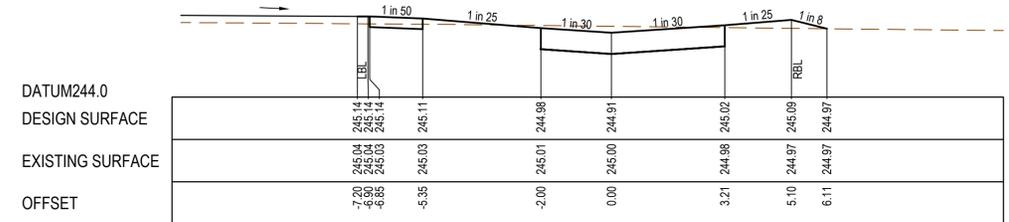

CH 42.00

HUB LANE

REV	DATE	AMENDMENT / REVISION DESCRIPTION	DESIGN	APPROVAL
0	05.10.18	ISSUED FOR CONSTRUCTION	PM/RB	AB

All setting out should be carried out in accordance with MPA/Council's standard drawings or as nominated on hard copy plans provided by SMEC. Any digital information supplied by this office is for information only. Any discrepancies should be discussed with the superintendent.

TITLE	NAME
DRAFTER	R.Barua
DESIGNER	P.McKay
CHECKED	Z.Gosev
AUTHORISED	A.Burrows
SMEC DRAWING REF.	1700E-04
MELBOURNE WATER REF.	388/3079

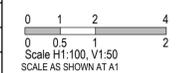

Olivine Estate - Stage 4  
Whittlesea City Council  
Road and Drainage  
Cross Sections: Degree Lane & Hub Lane

MELBOURNE REF	PROJECT / DRAWING No	SHEET No	REVISION
8 M2	1700E-04-19	19 of 45	0







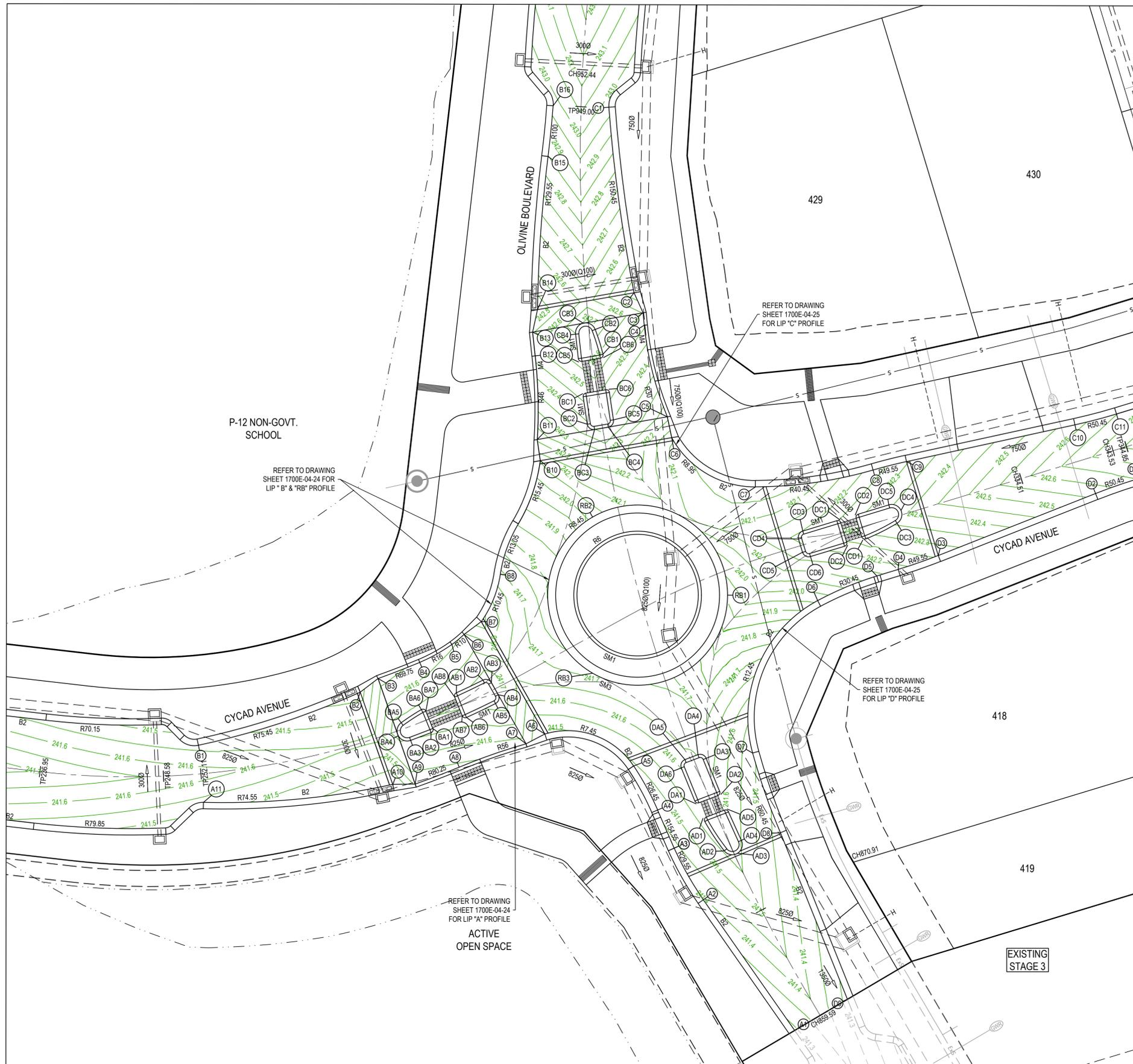

Alignment AB

Point no	Easting	Northing	RL
AB1	323072.393	5843249.311	241.686
AB2	323074.892	5843250.507	241.714
AB3	323075.683	5843250.267	241.731
AB4	323076.326	5843249.135	241.739
AB5	323076.073	5843248.303	241.721
AB6	323073.343	5843246.997	241.678
AB7	323072.940	5843247.157	241.683
AB8	323072.227	5843248.920	241.690

Curve no	I	Radius	Arc	A	B	X	Y	I	Mid point RL
AB1-AB2	2.153	73.750	2.771	0.013	0.010	0.693	0.693	0.693	241.700
AB2-AB3	87.070	0.600	0.912	0.165	0.122	0.223	0.191	0.228	241.723
AB4-AB5	92.880	0.600	0.973	0.187	0.138	0.237	0.196	0.243	241.731
AB5-AB6	2.275	76.250	3.027	0.015	0.011	0.757	0.757	0.757	241.691
AB6-AB7	92.403	0.300	0.484	0.092	0.068	0.118	0.099	0.121	241.678
AB8-AB1	89.871	0.300	0.471	0.088	0.065	0.115	0.097	0.118	241.686

Alignment AD

Point no	Easting	Northing	RL
AD1	323095.573	5843237.543	241.573
AD2	323097.571	5843234.484	241.555
AD3	323096.814	5843234.266	241.562
AD4	323098.177	5843235.475	241.544
AD5	323097.855	5843238.405	241.592

Curve no	I	Radius	Arc	A	B	X	Y	I	Mid point RL
AD1-AD2	10.482	20.000	3.659	0.084	0.063	0.914	0.913	0.915	241.563
AD2-AD3	83.260	0.950	1.380	0.240	0.178	0.338	0.294	0.345	241.563
AD3-AD4	83.260	0.950	1.380	0.240	0.178	0.338	0.294	0.345	241.546
AD4-AD5	1.238	148.750	3.215	0.009	0.007	0.804	0.804	0.804	241.568

Alignment BA

Point no	Easting	Northing	RL
BA1	323070.184	5843245.972	241.667
BA2	323070.017	5843245.581	241.656
BA3	323068.098	5843244.847	241.646
BA4	323066.934	5843245.289	241.670
BA5	323067.209	5843245.504	241.689
BA6	323068.120	5843247.747	241.664
BA7	323068.139	5843247.754	241.664
BA8	323069.530	5843247.589	241.674

Curve no	I	Radius	Arc	A	B	X	Y	I	Mid point RL
BA1-BA2	90.313	0.300	0.473	0.088	0.065	0.115	0.098	0.118	241.661
BA2-BA3	1.543	76.250	2.054	0.007	0.005	0.514	0.514	0.514	241.651
BA3-BA4	81.938	0.950	1.359	0.233	0.173	0.332	0.290	0.340	241.650
BA4-BA5	81.938	0.950	1.359	0.233	0.173	0.332	0.290	0.340	241.678
BA5-BA6	6.536	20.000	2.281	0.033	0.024	0.570	0.570	0.570	241.664
BA7-BA8	90.078	0.300	0.472	0.088	0.065	0.115	0.097	0.118	241.668

Alignment BC

Point no	Easting	Northing	RL
BC1	323084.268	5843277.366	242.472
BC2	323084.692	5843274.506	242.392
BC3	323086.388	5843274.008	242.398
BC4	323086.669	5843274.232	242.405
BC5	323087.158	5843274.916	242.398
BC6	323086.732	5843277.796	242.477

Curve no	I	Radius	Arc	A	B	X	Y	I	Mid point RL
BC1-BC2	1.095	151.250	2.891	0.007	0.005	0.723	0.723	0.723	242.432
BC2-BC3	90.908	0.600	0.952	0.179	0.133	0.232	0.196	0.238	242.388
BC4-BC5	89.084	0.600	0.933	0.172	0.128	0.227	0.193	0.233	242.395
BC5-BC6	1.121	148.750	2.911	0.007	0.005	0.728	0.728	0.728	242.437

Alignment CB

Point no	Easting	Northing	RL
CB1	323086.165	5843281.069	242.581
CB2	323085.431	5843283.389	242.684
CB3	323084.322	5843283.979	242.706
CB4	323083.599	5843282.952	242.657
CB5	323083.885	5843280.344	242.563
CB6	323086.221	5843280.752	242.570

Curve no	I	Radius	Arc	A	B	X	Y	I	Mid point RL
CB1-CB2	7.298	19.120	2.435	0.039	0.029	0.609	0.608	0.609	242.633
CB2-CB3	82.849	0.949	1.372	0.237	0.176	0.336	0.292	0.343	242.712
CB3-CB4	82.849	0.949	1.372	0.237	0.176	0.336	0.292	0.343	242.682

Alignment CD

Point no	Easting	Northing	RL
CD1	323109.166	5843263.151	242.250
CD2	323108.440	5843265.544	242.252
CD3	323104.947	5843264.484	242.200
CD4	323104.547	5843263.736	242.209
CD5	323104.925	5843262.492	242.175
CD6	323105.673	5843262.092	242.168

Curve no	I	Radius	Arc	A	B	X	Y	I	Mid point RL
CD3-CD4	90.000	0.600	0.942	0.176	0.130	0.230	0.195	0.236	242.204
CD5-CD6	90.000	0.600	0.942	0.176	0.130	0.230	0.195	0.236	242.166

Alignment DA

Point no	Easting	Northing	RL
DA1	323094.918	5843238.899	241.585
DA2	323097.259	5843239.783	241.615
DA3	323096.863	5843243.169	241.674
DA4	323096.094	5843243.509	241.664
DA5	323093.878	5843243.050	241.630
DA6	323093.532	5843242.267	241.603

Curve no	I	Radius	Arc	A	B	X	Y	I	Mid point RL
DA2-DA3	1.411	148.750	3.662	0.011	0.008	0.916	0.915	0.916	241.649
DA3-DA4	89.003	0.600	0.932	0.172	0.127	0.227	0.193	0.233	241.671
DA5-DA6	90.989	0.600	0.953	0.179	0.133	0.232	0.196	0.238	241.614
DA6-DA1	1.379	151.250	3.641	0.011	0.008	0.910	0.910	0.910	241.589

Alignment DC

Point no	Easting	Northing	RL
DC1	323109.876	5843265.979	242.280
DC2	323110.586	5843263.636	242.269
DC3	323113.803	5843265.216	242.357
DC4	323114.177	5843266.415	242.378
DC5	323113.034	5843266.937	242.341

Curve no	I	Radius	Arc	A	B	X	Y	I	Mid point RL
DC2-DC3	10.280	20.000	3.588	0.080	0.060	0.897	0.895	0.897	242.313
DC3-DC4	82.791	0.950	1.373	0.237	0.176	0.336	0.292	0.343	242.381
DC4-DC5	82.791	0.950	1.373	0.237	0.176	0.336	0.292	0.343	242.359

REV	DATE	AMENDMENT / REVISION DESCRIPTION	DESIGN	APPROVAL
0	05.10.18	ISSUED FOR CONSTRUCTION	PM/RB	AB

**ISSUED FOR CONSTRUCTION**

TITLE	NAME
DRAFTER	R.Barua
DESIGNER	P.McKay
CHECKED	Z.Gosev
AUTHORISED	A.Burrows
SMEC DRAWING REF.	1700E-04
MELBOURNE WATER REF.	388/3079

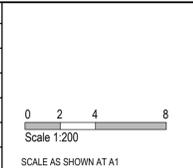

Olivine Estate - Stage 4  
Whittlesea City Council  
Road and Drainage  
Intersection Detail Plan & Lip Profiles - 1

MELBOURNE REF	PROJECT / DRAWING No.	SHEET No.	REVISION
8 M2	1700E-04-23	23 of 45	0

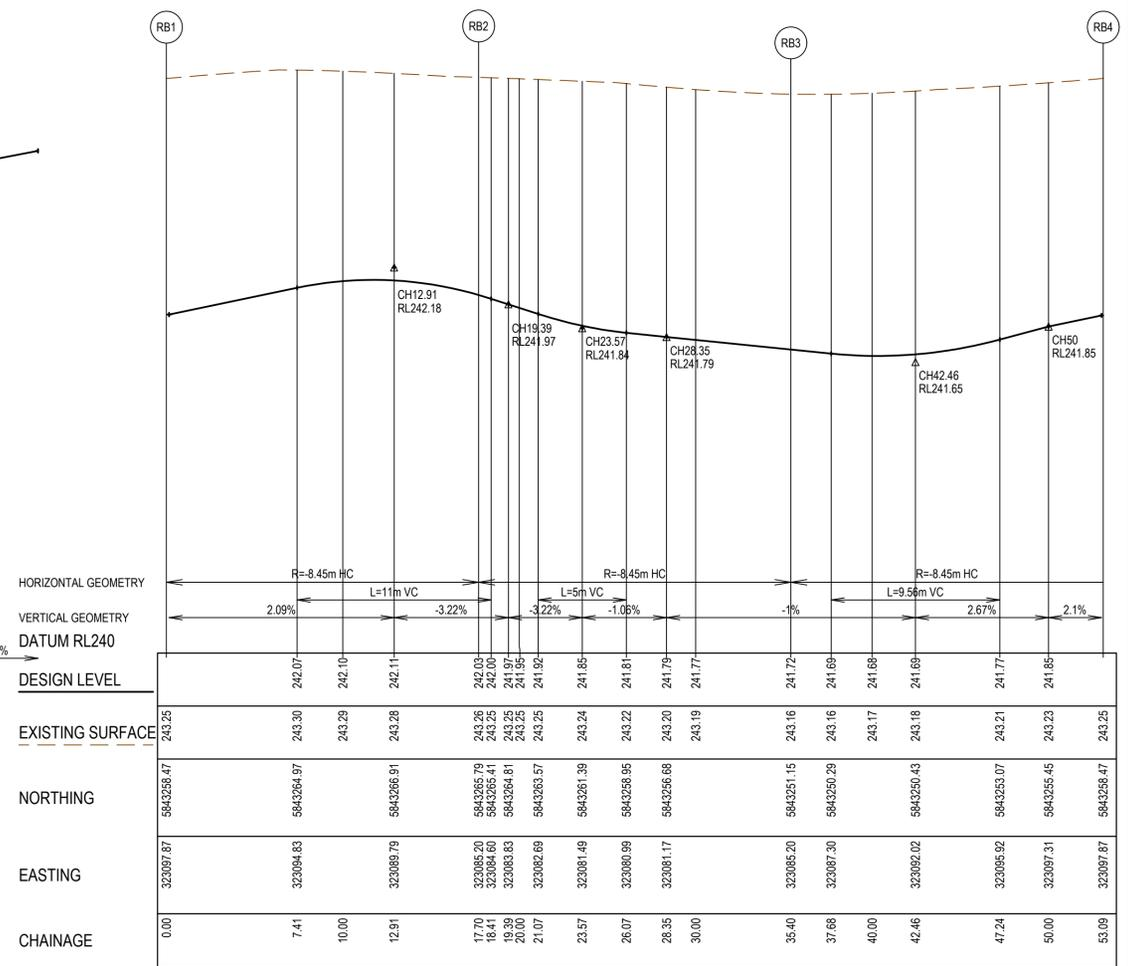
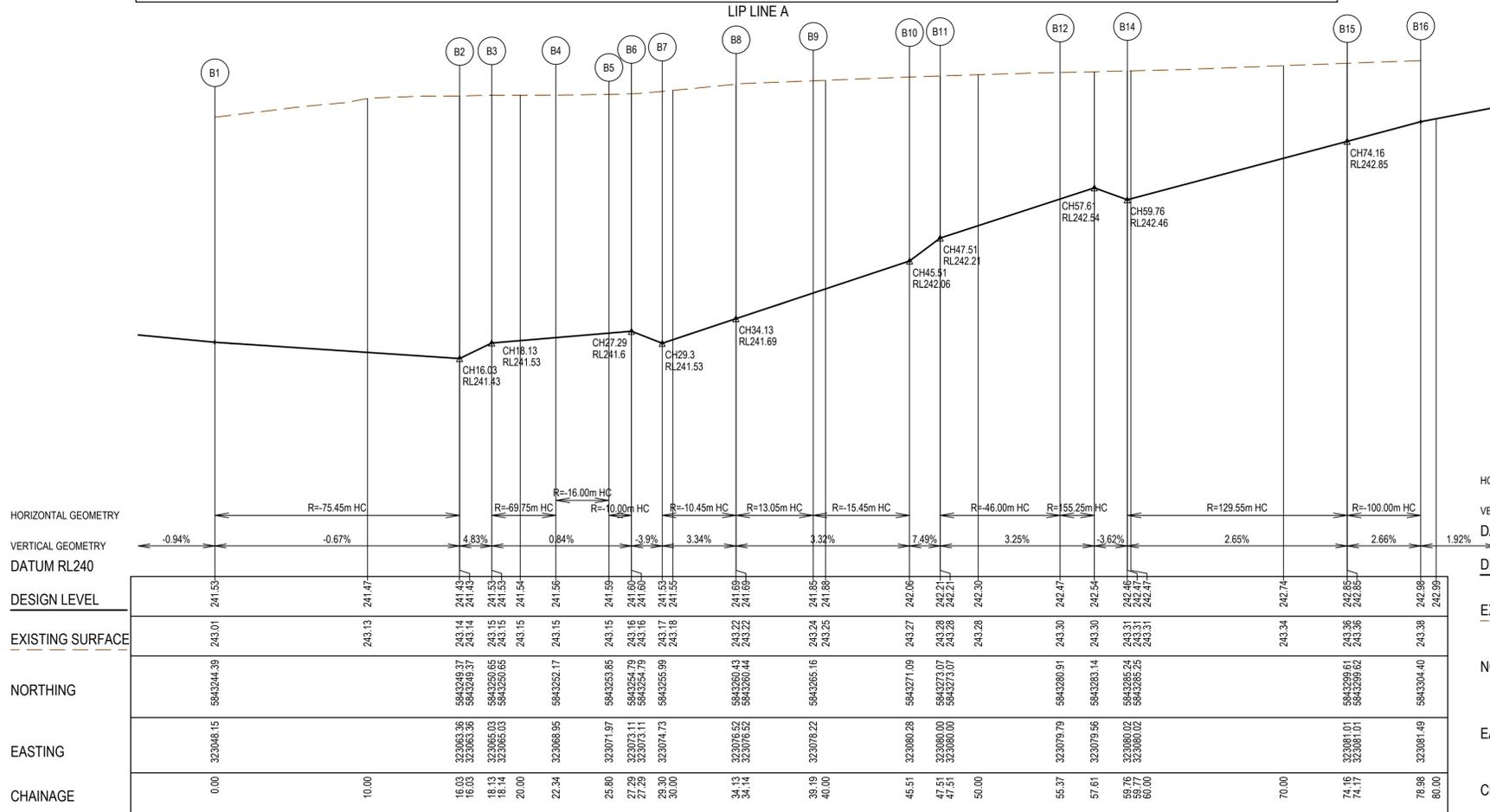
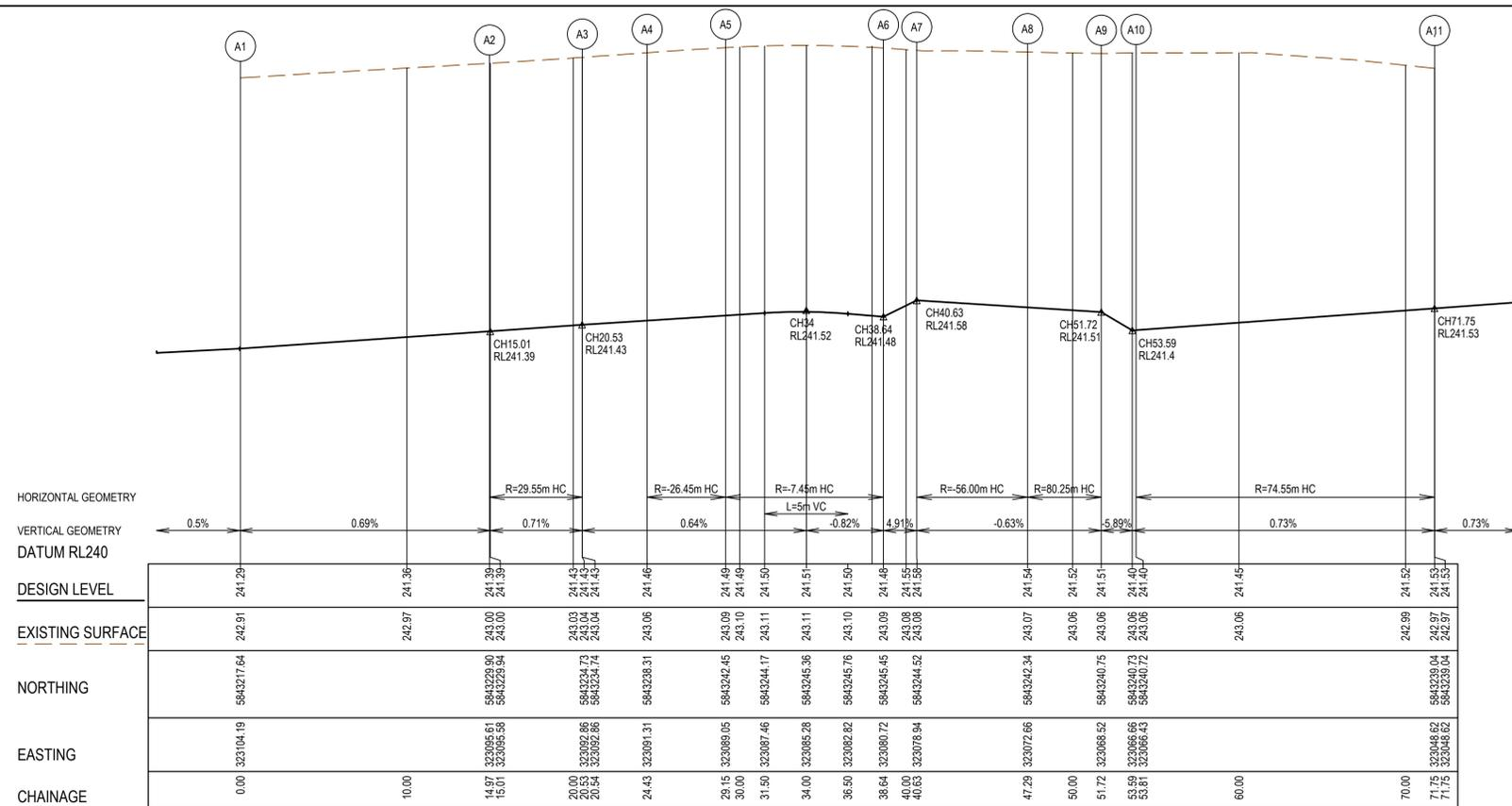

REV	DATE	AMENDMENT / REVISION DESCRIPTION	DESIGN	APPROVAL
0	05.10.18	ISSUED FOR CONSTRUCTION	PM/RB	AB

**ISSUED FOR CONSTRUCTION**

All setting out should be carried out in accordance with MPA/Council's standard drawings or as nominated on hard copy plans provided by SMEC. Any digital information supplied by this office is for information only. Any discrepancies should be discussed with the superintendent.

TITLE	NAME
DRAFTER	R.Barua
DESIGNER	P.McKay
CHECKED	Z.Gosev
AUTHORISED	A.Burrows
SMEC DRAWING REF.	1700E-04
MELBOURNE WATER REF.	388/3079

Scale H1:200, V1:20  
SCALE AS SHOWN AT 1

Member of the Surlana Jurong Group  
ABN 47 065 475 149  
Tower 4, Level 20, 727 Collins Street  
Docklands, VIC 3008  
Ph 03 9514 1500

Olivine Estate - Stage 4  
Whittlesea City Council  
Road and Drainage  
Intersection Detail Plan & Lip Profiles - 2

MELBOURNE REF <b>8 M2</b>	PROJECT / DRAWING No. <b>1700E-04-24</b>	SHEET No. <b>24 of 45</b>	REVISION <b>0</b>
------------------------------	---	------------------------------	----------------------



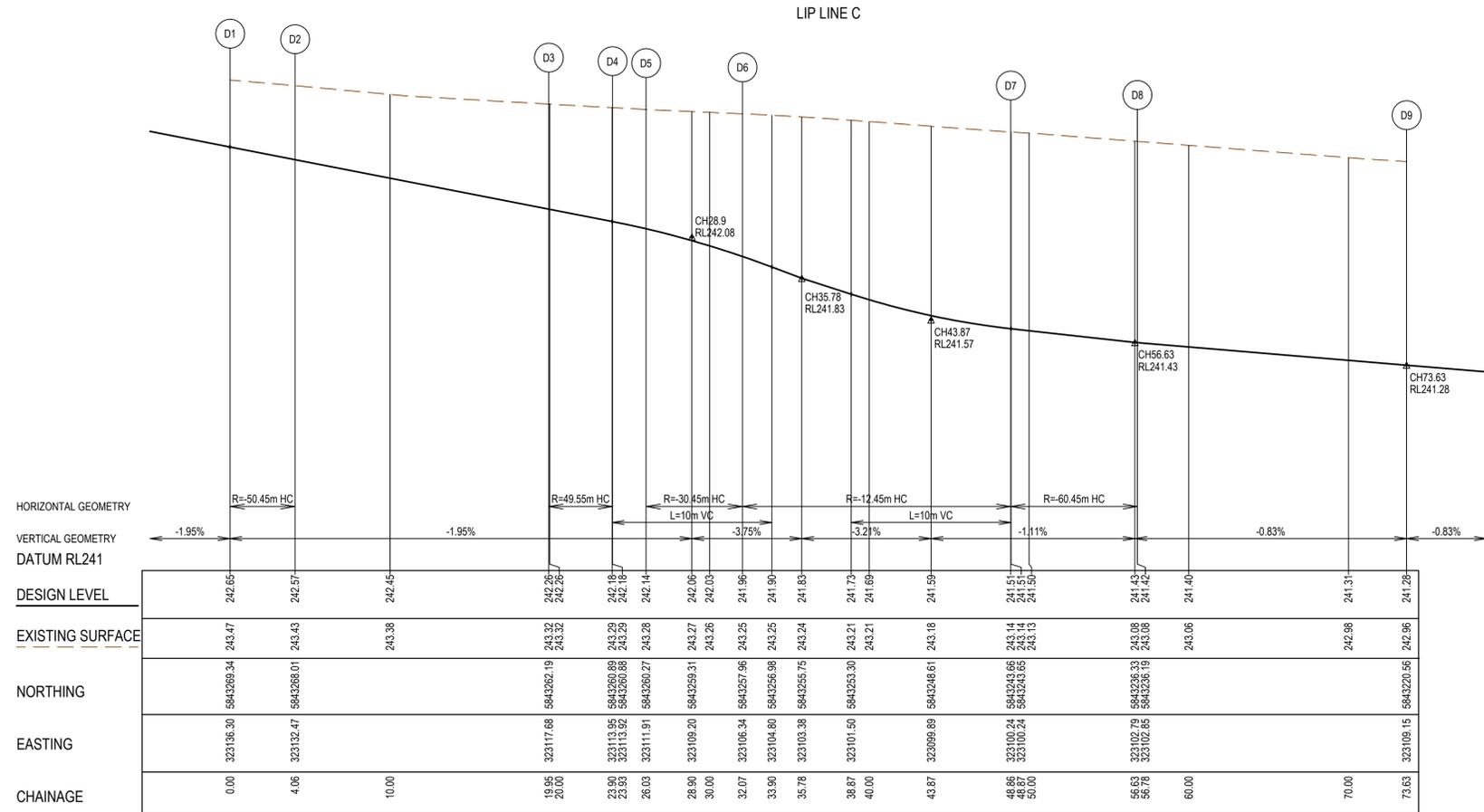
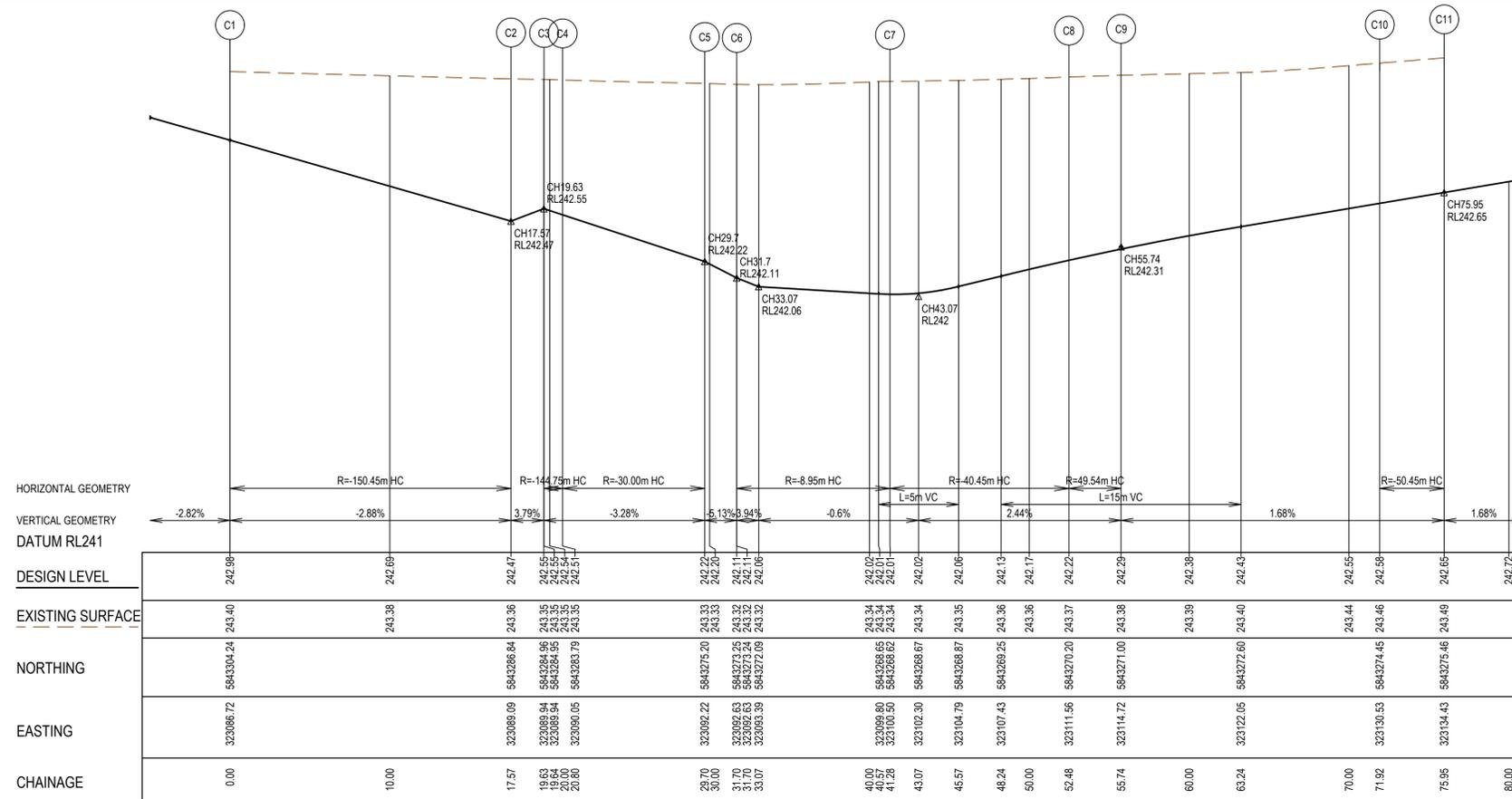

REV	DATE	AMENDMENT / REVISION DESCRIPTION	DESIGN	APPROVAL
0	05.10.18	ISSUED FOR CONSTRUCTION	PM/RB	AB

**ISSUED FOR CONSTRUCTION**

All setting out should be carried out in accordance with MPA/Council's standard drawings or as nominated on hard copy plans provided by SMEC. Any digital information supplied by this office is for information only. Any discrepancies should be discussed with the superintendent.

Quality Management ISO 9001  
 OHS Management AS/NZS 1881  
 Environmental Management ISO 14001

Global-Mark.com.au®

TITLE	NAME
DRAFTER	R.Barua
DESIGNER	P.McKay
CHECKED	Z.Gosev
AUTHORISED	A.Burrows
SMEC DRAWING REF.	1700E-04
MELBOURNE WATER REF.	388/3079



**SMEC**  
 Member of the Surlana Jurong Group  
 ABN 47 065 475 149  
 Tower 4, Level 20, 727 Collins Street  
 Docklands, VIC 3008  
 Ph 03 9514 1500

**mirvac**

Olivine Estate - Stage 4  
 Whittlesea City Council  
 Road and Drainage  
 Intersection Detail Plan & Lip Profiles - 3

MELWAYS REF <b>8 M2</b>	PROJECT / DRAWING No. <b>1700E-04-25</b>	SHEET No. <b>25 of 45</b>	REVISION <b>0</b>
----------------------------	---	------------------------------	----------------------

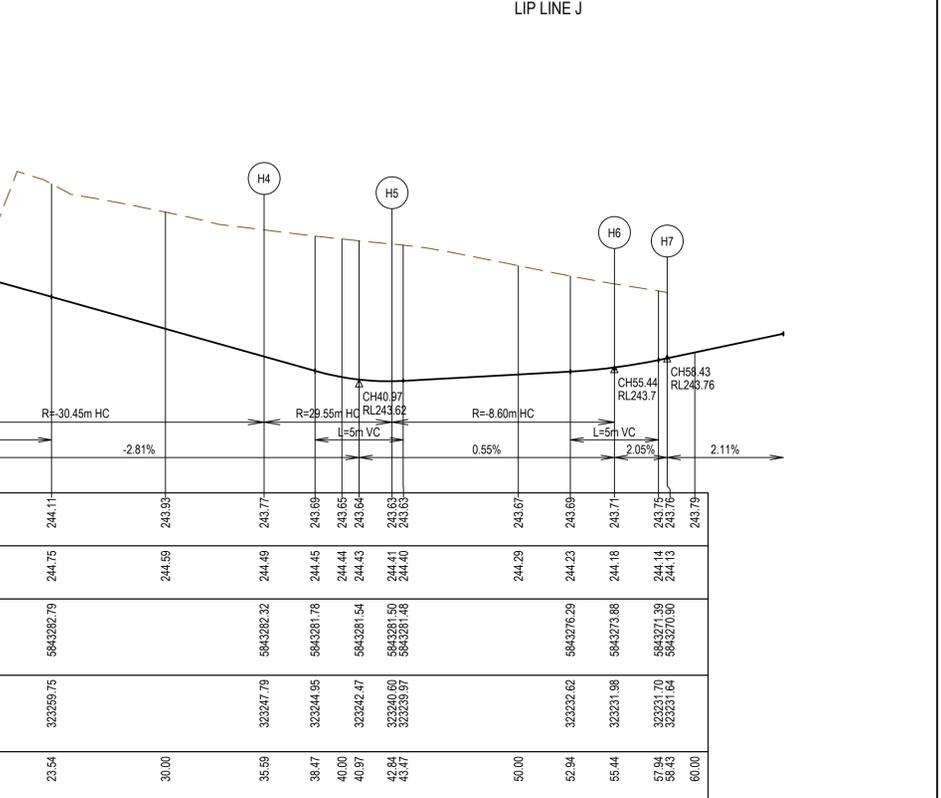
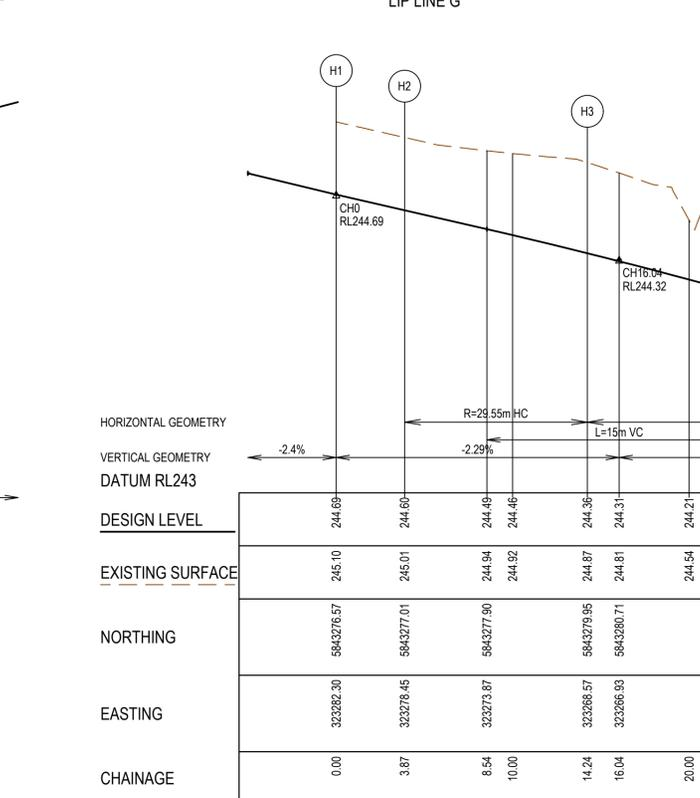
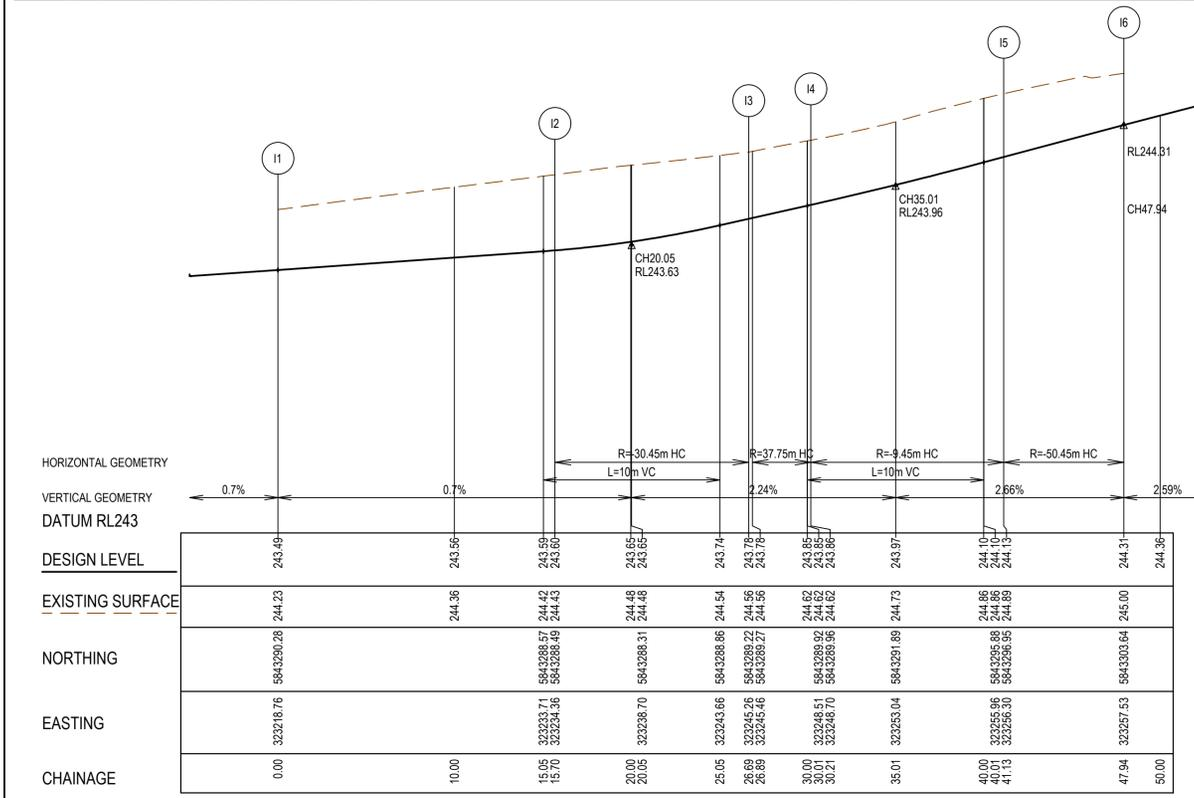
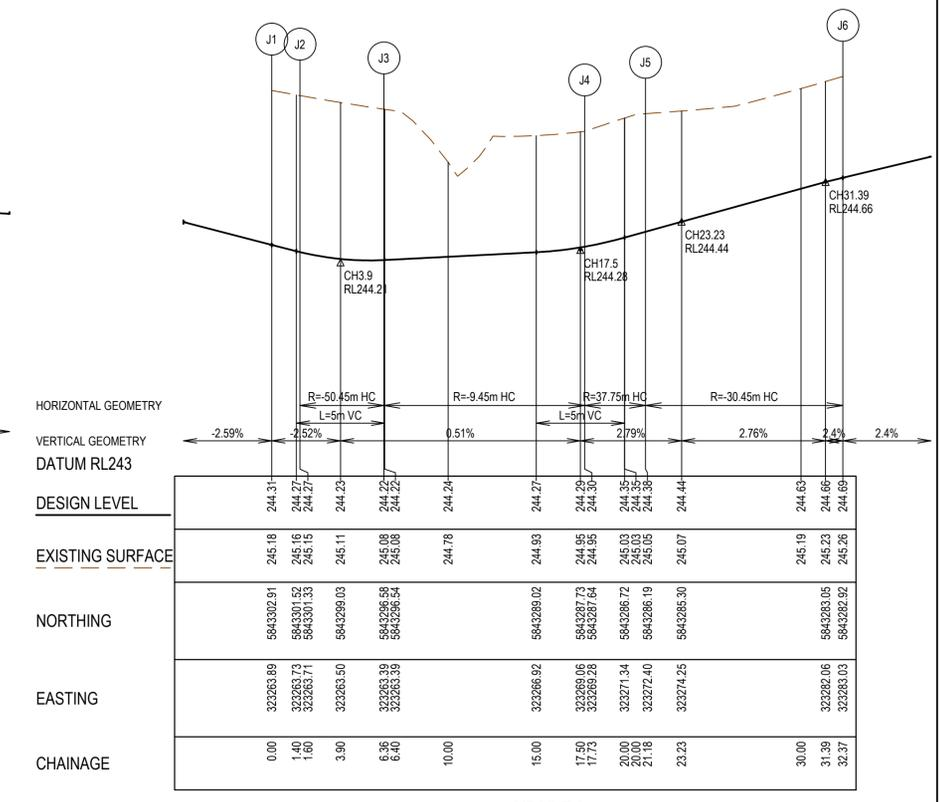
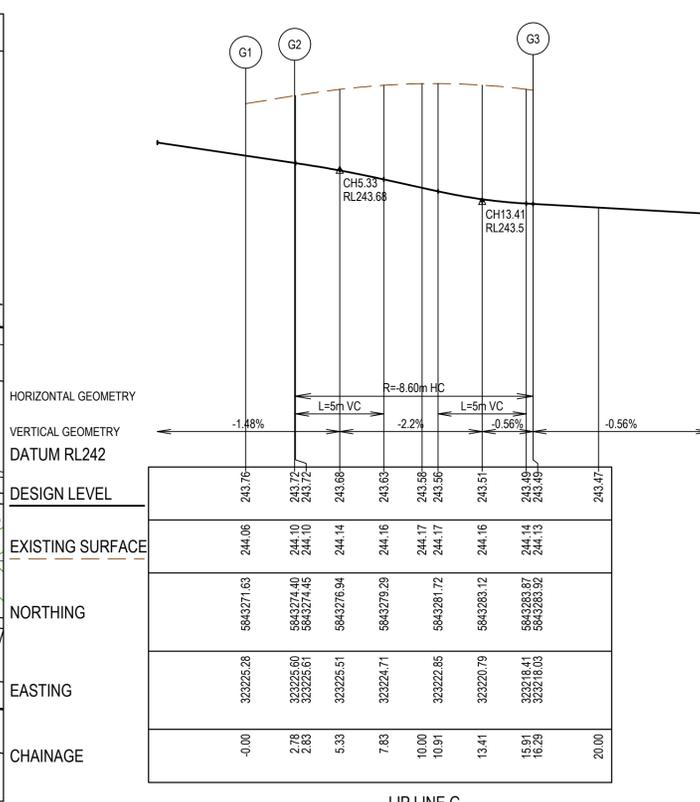
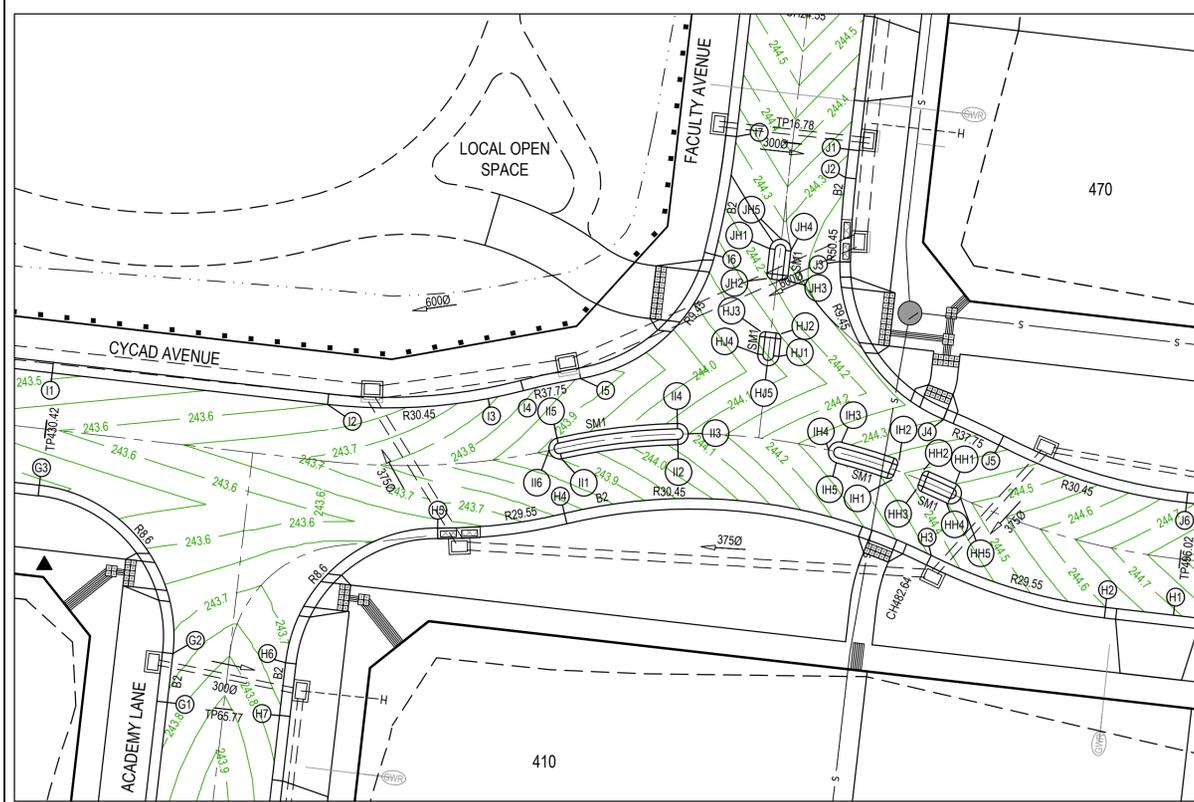

Alignment II

Point no	Easting	Northing	RL
I1	323247.627	5843285.418	243.902
I2	323254.209	5843286.215	244.064
I3	323254.796	5843286.838	244.099
I4	323254.184	5843287.415	244.066
I5	323247.365	5843286.589	243.906
I6	323246.911	5843285.872	243.913

Alignment HJ

Point no	Easting	Northing	RL
HJ1	323259.932	5843291.203	244.155
HJ2	323260.080	5843292.495	244.155
HJ3	323258.888	5843292.631	244.119
HJ4	323258.740	5843291.339	244.087
HJ5	323259.268	5843290.675	244.085

Alignment JH

Point no	Easting	Northing	RL
JH1	323259.422	5843297.300	244.238
JH2	323259.729	5843295.612	244.195
JH3	323260.421	5843295.475	244.233
JH4	323260.614	5843297.164	244.271
JH5	323260.086	5843297.828	244.273

Alignment IH

Point no	Easting	Northing	RL
IH1	323266.335	5843284.220	244.368
IH2	323266.751	5843285.346	244.367
IH3	323263.465	5843286.351	244.287
IH4	323262.745	5843285.917	244.292
IH5	323263.189	5843285.188	244.287

Alignment HI

Point no	Easting	Northing	RL
HI1	323269.941	5843284.006	244.449
HI2	323268.159	5843284.801	244.403
HI3	323267.725	5843283.651	244.404
HI4	323268.421	5843282.953	244.445
HI5	323270.222	5843283.206	244.474

Curve data for Alignment II:

Curve no	I	Radius	Arc	A	B	X	Y	I	Mid point RL
I1-I2	11.359	33.500	6.641	0.164	0.123	1.660	1.656	1.660	243.982
I2-I3	90.000	0.600	0.942	0.176	0.130	0.230	0.195	0.236	244.080
I3-I4	90.000	0.600	0.942	0.176	0.130	0.230	0.195	0.236	244.082
I4-I5	11.359	34.700	6.879	0.170	0.128	1.719	1.715	1.720	243.986
I5-I6	90.000	0.600	0.942	0.176	0.130	0.230	0.195	0.236	243.904
I6-I1	90.000	0.600	0.942	0.176	0.130	0.230	0.195	0.236	243.900

Curve data for Alignment HJ:

Curve no	I	Radius	Arc	A	B	X	Y	I	Mid point RL
HJ4-HJ5	90.000	0.600	0.942	0.176	0.130	0.230	0.195	0.236	244.080
HJ5-HJ1	90.000	0.600	0.942	0.176	0.130	0.230	0.195	0.236	244.100

Curve data for Alignment JH:

Curve no	I	Radius	Arc	A	B	X	Y	I	Mid point RL
JH4-JH5	90.000	0.600	0.942	0.176	0.130	0.230	0.195	0.236	244.276
JH5-JH1	90.000	0.600	0.942	0.176	0.130	0.230	0.195	0.236	244.255

Curve data for Alignment IH:

Curve no	I	Radius	Arc	A	B	X	Y	I	Mid point RL
IH2-IH5	5.645	34.700	3.419	0.042	0.032	0.855	0.854	0.855	244.327
IH3-IH4	90.000	0.600	0.942	0.176	0.130	0.230	0.195	0.236	244.283
IH4-IH5	90.000	0.600	0.942	0.176	0.130	0.230	0.195	0.236	244.283
IH5-IH1	5.632	33.500	3.293	0.040	0.030	0.823	0.823	0.823	244.327

Curve data for Alignment HI:

Curve no	I	Radius	Arc	A	B	X	Y	I	Mid point RL
HI1-HI2	3.222	34.700	1.951	0.014	0.010	0.488	0.488	0.488	244.426
HI3-HI4	3.177	33.500	1.858	0.013	0.010	0.464	0.464	0.464	244.426
HI4-HI5	90.000	0.600	0.942	0.176	0.130	0.230	0.195	0.236	244.466
HI5-HI1	90.000	0.600	0.942	0.176	0.130	0.230	0.195	0.236	244.466

ISSUED FOR CONSTRUCTION

REV	DATE	AMENDMENT / REVISION DESCRIPTION	DESIGN	APPROVAL
0	05.10.18	ISSUED FOR CONSTRUCTION	PM/RB	AB

All setting out should be carried out in accordance with MPA/Council's standard drawings or as nominated on hard copy plans provided by SMEC. Any digital information supplied by this office is for information only. Any discrepancies should be discussed with the superintendent.

TITLE	NAME
DRAFTER	R.Barua
DESIGNER	P.McKay
CHECKED	Z.Gosev
AUTHORISED	A.Burrows
SMEC DRAWING REF.	1700E-04
MELBOURNE WATER REF.	388/3079

SMEC  
Member of the Surlana Jurong Group  
ABN 47 065 475 149  
Tower 4, Level 20, 727 Collins Street  
Docklands, VIC 3008  
Ph 03 9514 1500

Olivine Estate - Stage 4  
Whittlesea City Council  
Road and Drainage  
Intersection Detail Plan & Lip Profiles - 4

MELWAYS REF	PROJECT / DRAWING No	SHEET No	REVISION
8 M2	1700E-04-26	26 of 45	0

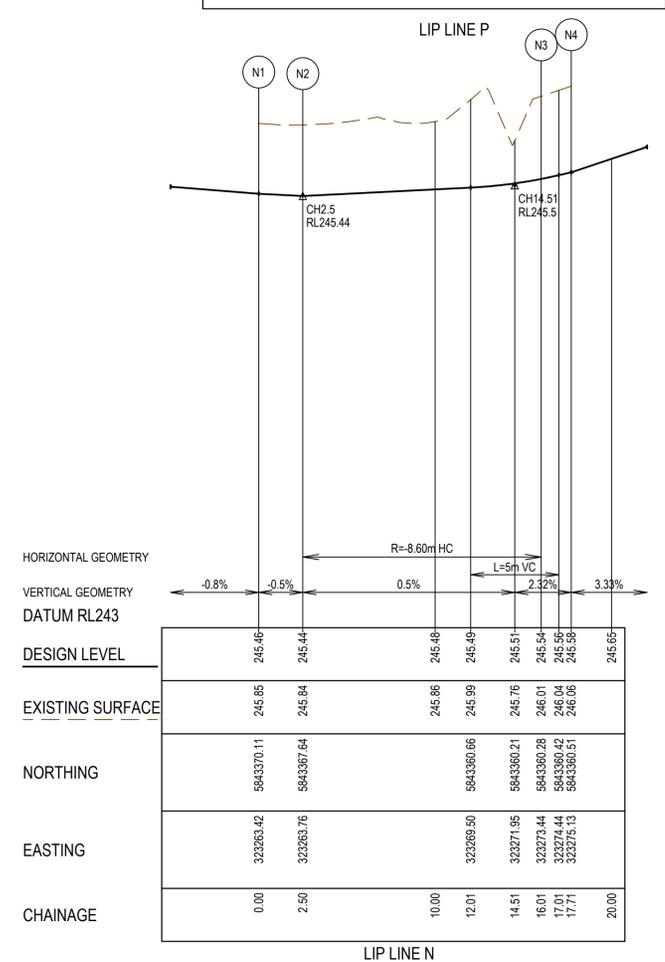
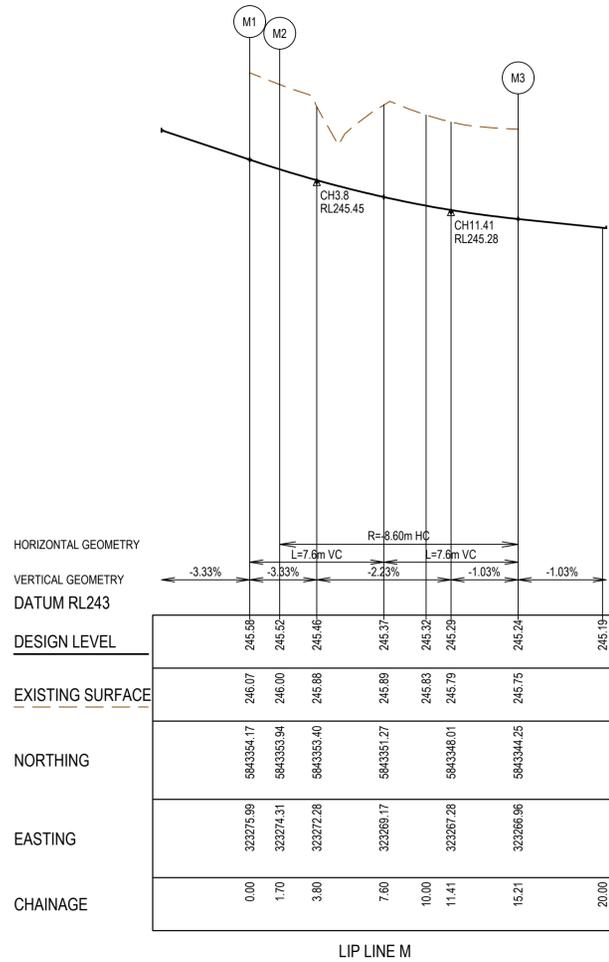
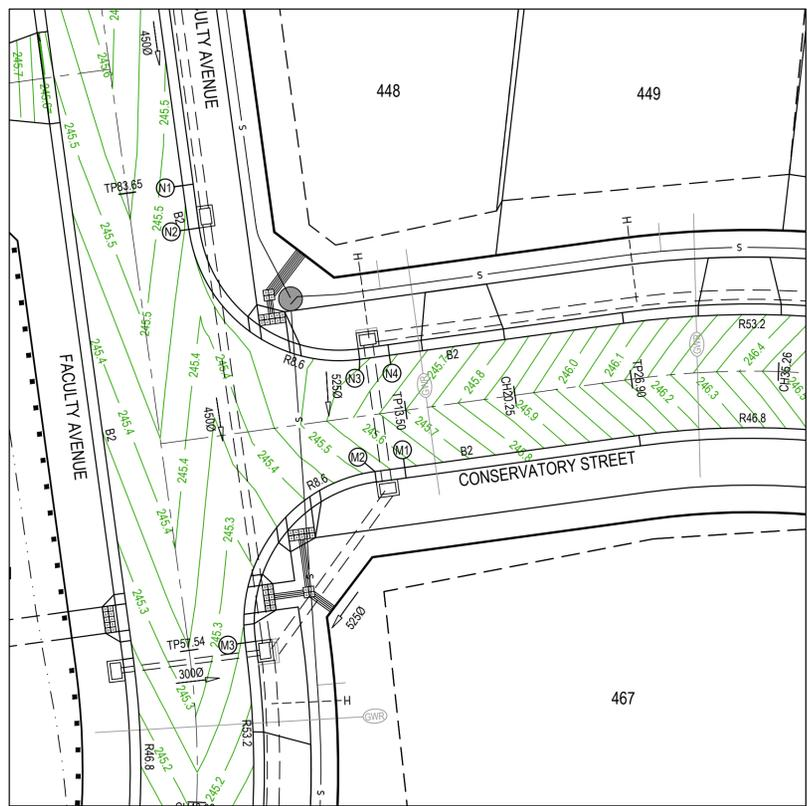
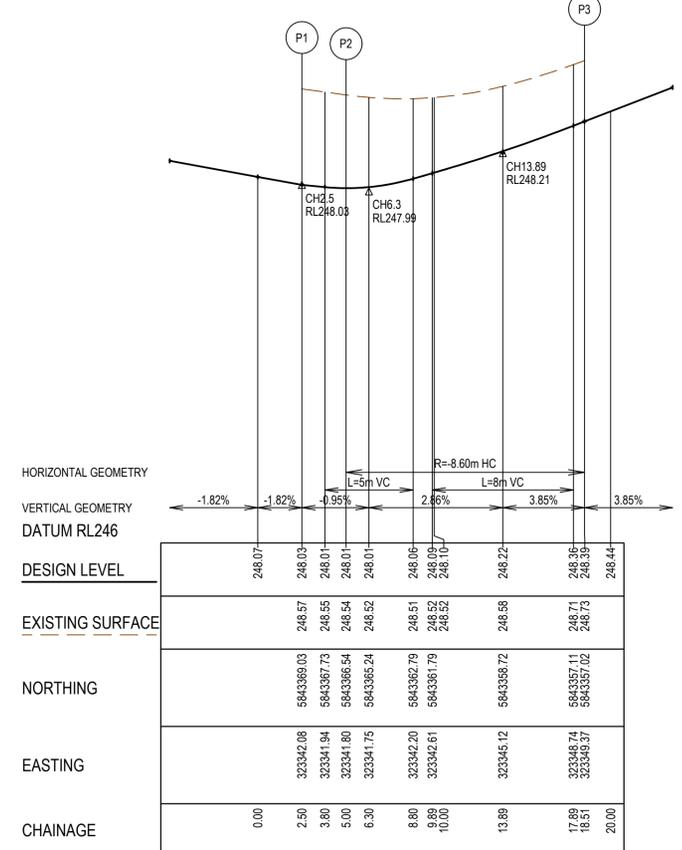
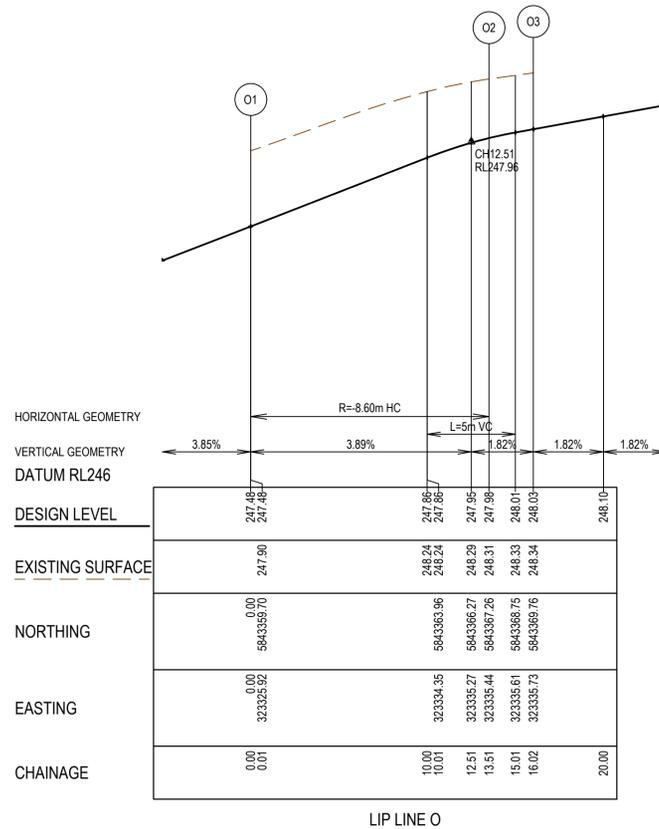
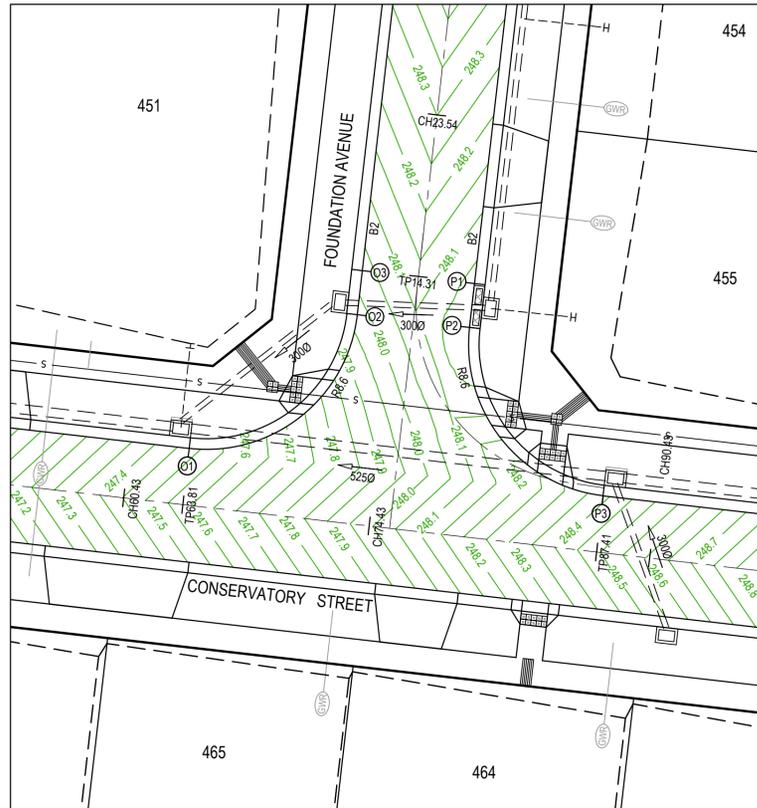

ISSUED FOR CONSTRUCTION

Quality Management ISO 9001  
 OHS Management AS/NZS 1881  
 Environmental Management ISO 14001

TITLE: LIP  
 NAME: R.Barua  
 DRAFTER: P.McKay  
 DESIGNER: Z.Gosev  
 CHECKED: A.Burrows  
 AUTHORISED: S.MEC DRAWING REF. 1700E-04  
 MELBOURNE WATER REF. 388/3079

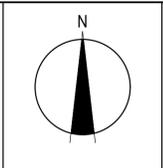
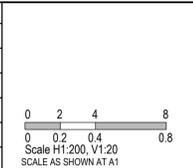

**SMEC**  
 Member of the Surlana Jurong Group  
 Tower 4, Level 20, 727 Collins Street  
 Docklands, VIC 3008  
 Ph 03 9514 1500



Olivine Estate - Stage 4  
 Whittlesea City Council  
 Road and Drainage  
 Intersection Detail Plan & Lip Profiles - 5

MELBOURNE REF: 8 M2  
 PROJECT / DRAWING No: 1700E-04-27  
 SHEET No: 27 of 45  
 REVISION: 0

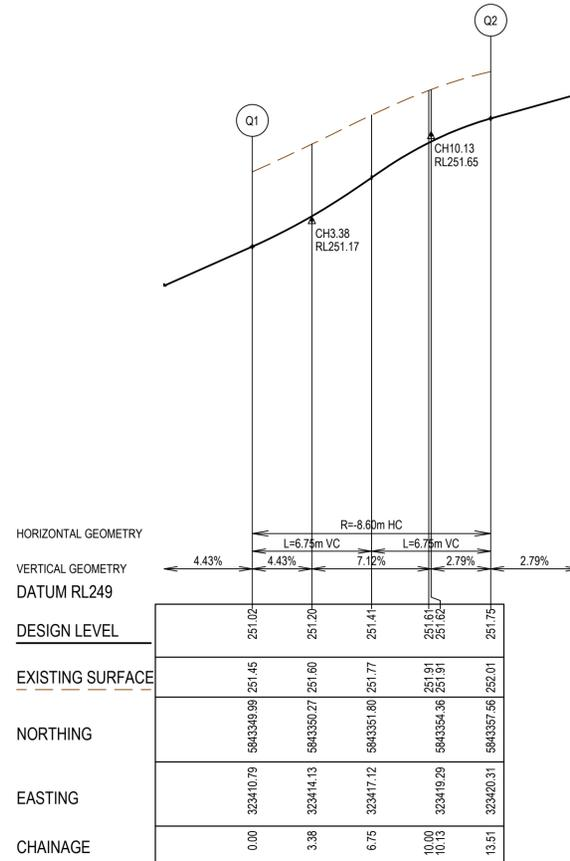
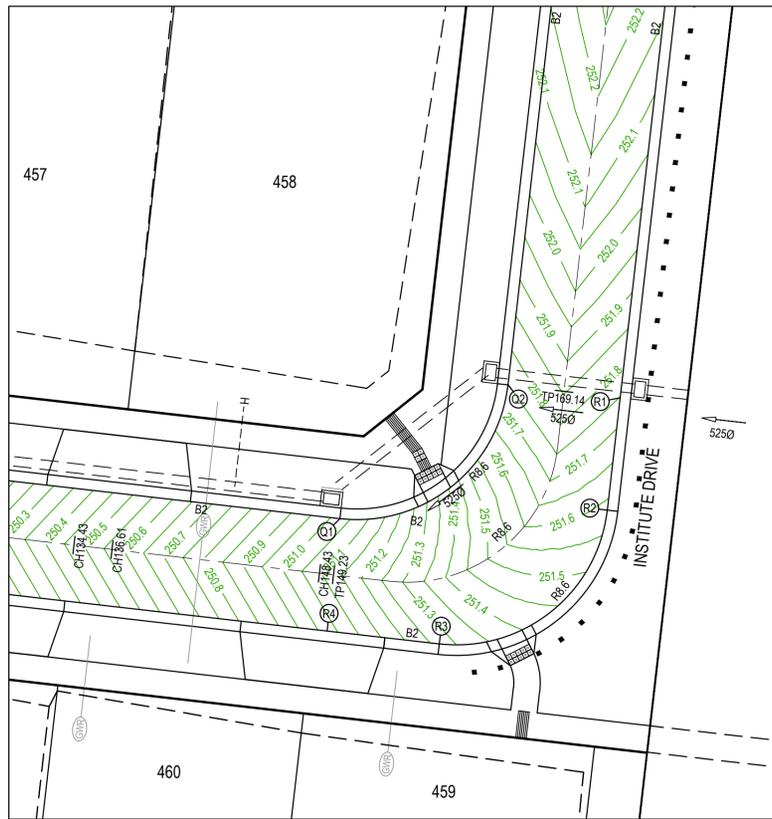

LIP LINE Q

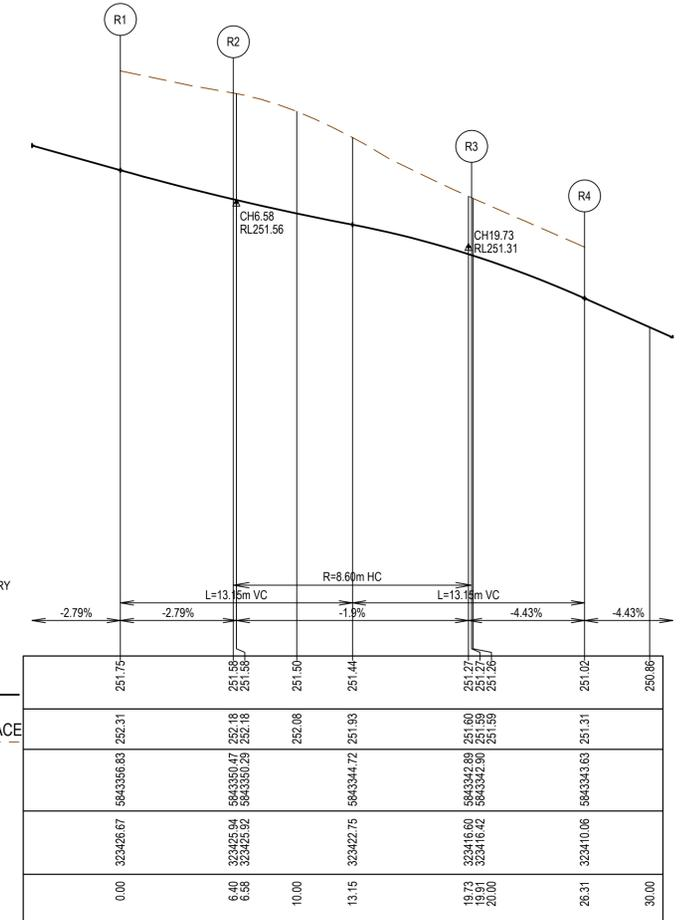

LIP LINE R

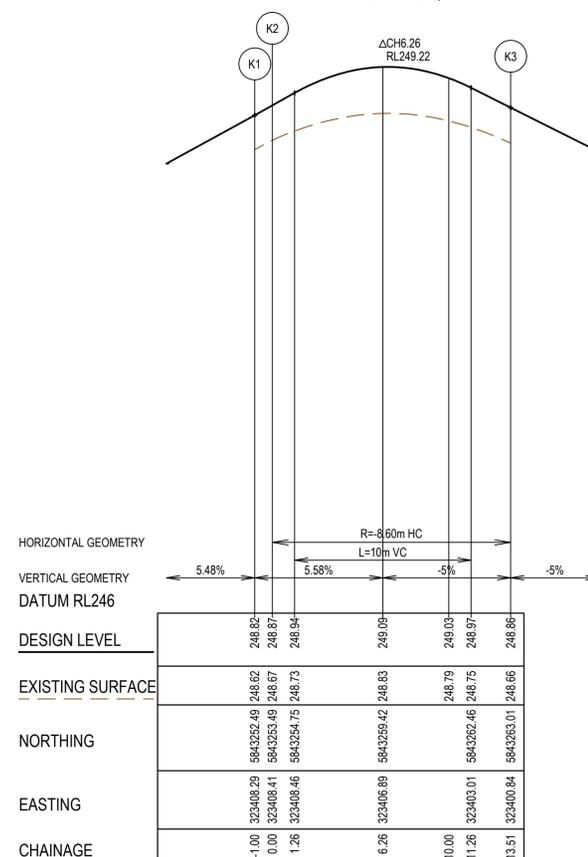

LIP LINE K

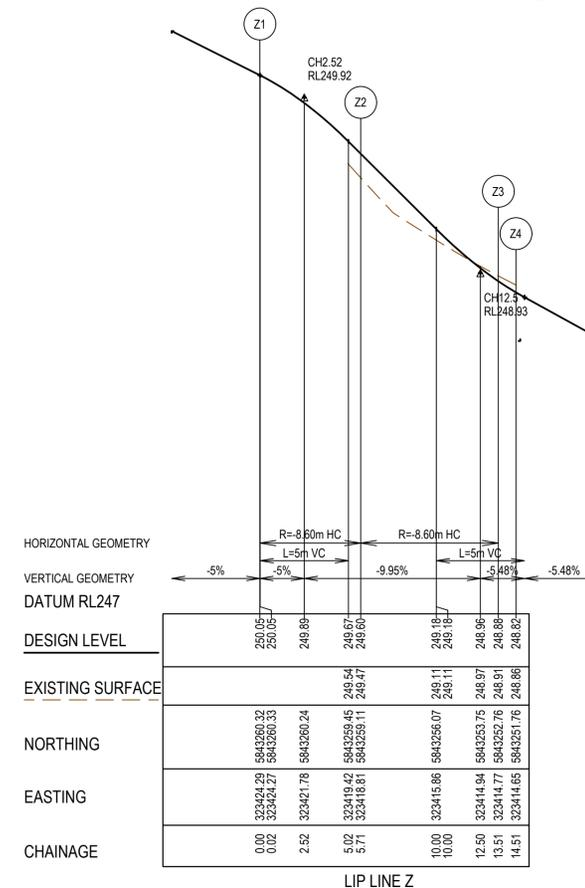

LIP LINE Z

REV	DATE	AMENDMENT / REVISION DESCRIPTION	DESIGN	APPROVAL
0	05.10.18	ISSUED FOR CONSTRUCTION	PM/RB	AB

All setting out should be carried out in accordance with MPA/Council's standard drawings or as nominated on hard copy plans provided by SMEC. Any digital information supplied by this office is for information only. Any discrepancies should be discussed with the superintendent.

TITLE	NAME
DRAFTER	R.Barua
DESIGNER	P.McKay
CHECKED	Z.Gosev
AUTHORISED	A.Burrows
SMEC DRAWING REF.	1700E-04
MELBOURNE WATER REF.	388/3079

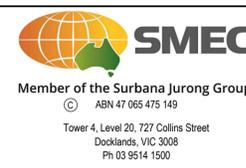
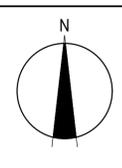
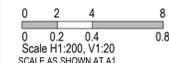

Olivine Estate - Stage 4  
Whittlesea City Council  
Road and Drainage  
Intersection Detail Plan & Lip Profiles - 6

MELWAYS REF	PROJECT / DRAWING No.	SHEET No.	REVISION
8 M2	1700E-04-28	28 of 45	0



Alignment S

Point no	Easting	Northing	RL
S1	323183.640	5843385.161	244.640
S2	323192.035	5843384.196	244.692
S3	323193.014	5843387.456	244.832
S4	323196.491	5843387.056	244.867
S5	323196.704	5843383.660	244.739
S6	323204.453	5843382.769	244.818
S7	323205.432	5843386.029	244.958
S8	323208.909	5843385.629	244.993
S9	323208.274	5843380.105	244.799
S10	323208.905	5843377.897	244.879
S11	323206.947	5843376.343	244.920
S12	323206.388	5843377.047	244.894
S13	323203.043	5843378.905	244.808
S14	323202.049	5843379.019	244.798
S15	323199.723	5843377.173	244.846
S16	323188.597	5843378.451	244.733
S17	323186.750	5843380.777	244.642
S18	323183.184	5843381.187	

Curve no	L	Radius	Arc	A	B	X	Y	I	Mid point RL
S9 - S10	45.000	3.000	2.356	0.228	0.171	0.585	0.563	0.589	244.839
S12 - S13	45.000	5.000	3.927	0.381	0.285	0.975	0.938	0.982	244.840

Alignment T

Point no	Easting	Northing	RL
T1	323251.666	5843373.748	
T2	323246.434	5843373.919	245.741
T3	323244.108	5843372.072	245.707
T4	323227.022	5843374.036	245.203
T5	323225.175	5843376.362	245.099
T6	323222.038	5843376.722	245.051
T7	323218.358	5843375.671	245.047
T8	323217.655	5843375.112	245.059
T9	323216.100	5843377.070	244.973
T10	323217.215	5843379.077	244.914
T11	323217.850	5843384.602	245.110
T12	323221.327	5843384.202	245.162
T13	323221.541	5843380.806	245.037
T14	323230.035	5843379.830	245.170
T15	323231.013	5843383.089	245.313
T16	323237.968	5843382.290	245.497
T17	323238.181	5843378.893	245.383
T18	323246.891	5843377.893	245.724
T19	323251.123	5843377.729	

Curve no	L	Radius	Arc	A	B	X	Y	I	Mid point RL
T1 - T2	9.384	31.998	5.241	0.107	0.080	1.310	1.308	1.310	245.771
T6 - T7	45.000	5.000	3.927	0.381	0.285	0.975	0.938	0.982	245.035
T9 - T10	45.000	3.000	2.356	0.228	0.171	0.585	0.563	0.589	244.944
T18 - T19	8.674	28.000	4.239	0.080	0.060	1.059	1.058	1.060	245.774

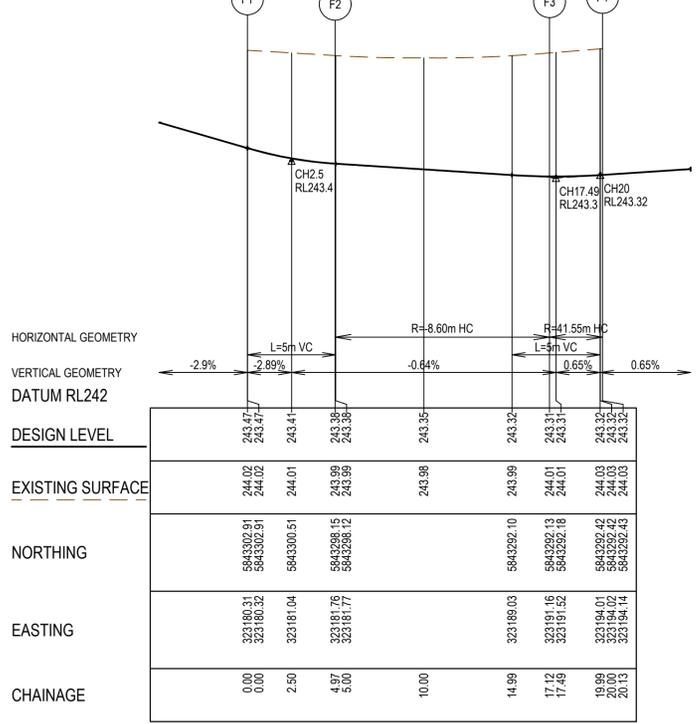
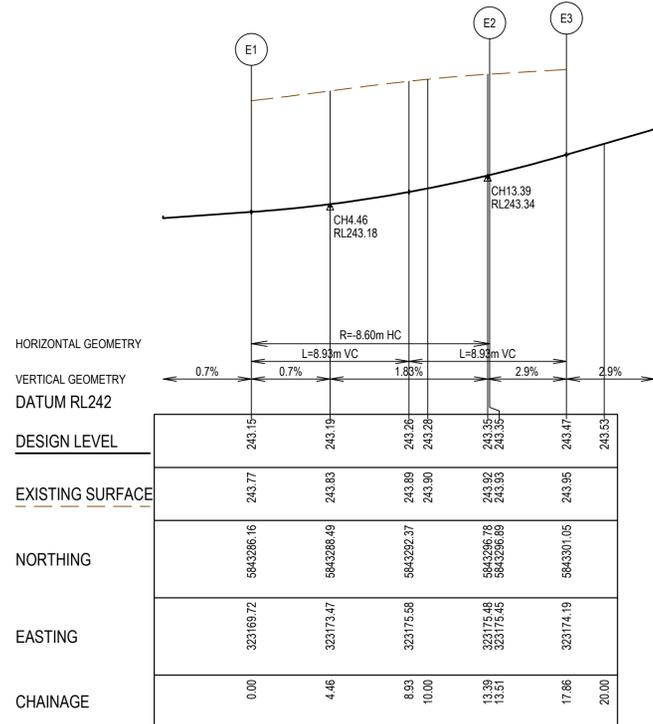
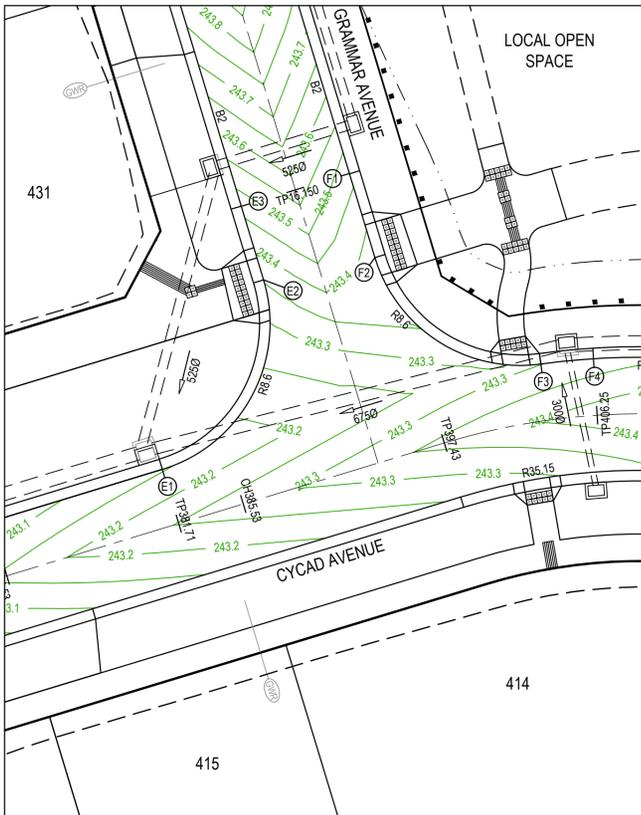

REV	DATE	AMENDMENT / REVISION DESCRIPTION	DESIGN	APPROVAL
0	05.10.18	ISSUED FOR CONSTRUCTION	PM/RB	AB

All setting out should be carried out in accordance with MPA/Council's standard drawings or as nominated on hard copy plans provided by SMEC. Any digital information supplied by this office is for information only. Any discrepancies should be discussed with the superintendent.

TITLE	NAME
DRAFTER	R.Barua
DESIGNER	P.McKay
CHECKED	Z.Gosev
AUTHORISED	A.Burrows
SMEC DRAWING REF.	1700E-04
MELBOURNE WATER REF.	388/3079

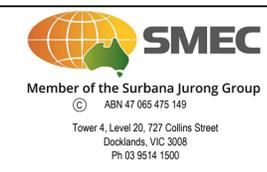
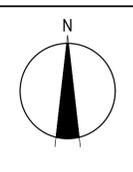
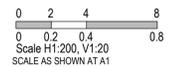

Olivine Estate - Stage 4  
Whittlesea City Council  
Road and Drainage  
Intersection Detail Plan & Lip Profiles - 7

MELBOURNE REF	PROJECT / DRAWING No	SHEET No	REVISION
8 M2	1700E-04-29	29 of 45	0



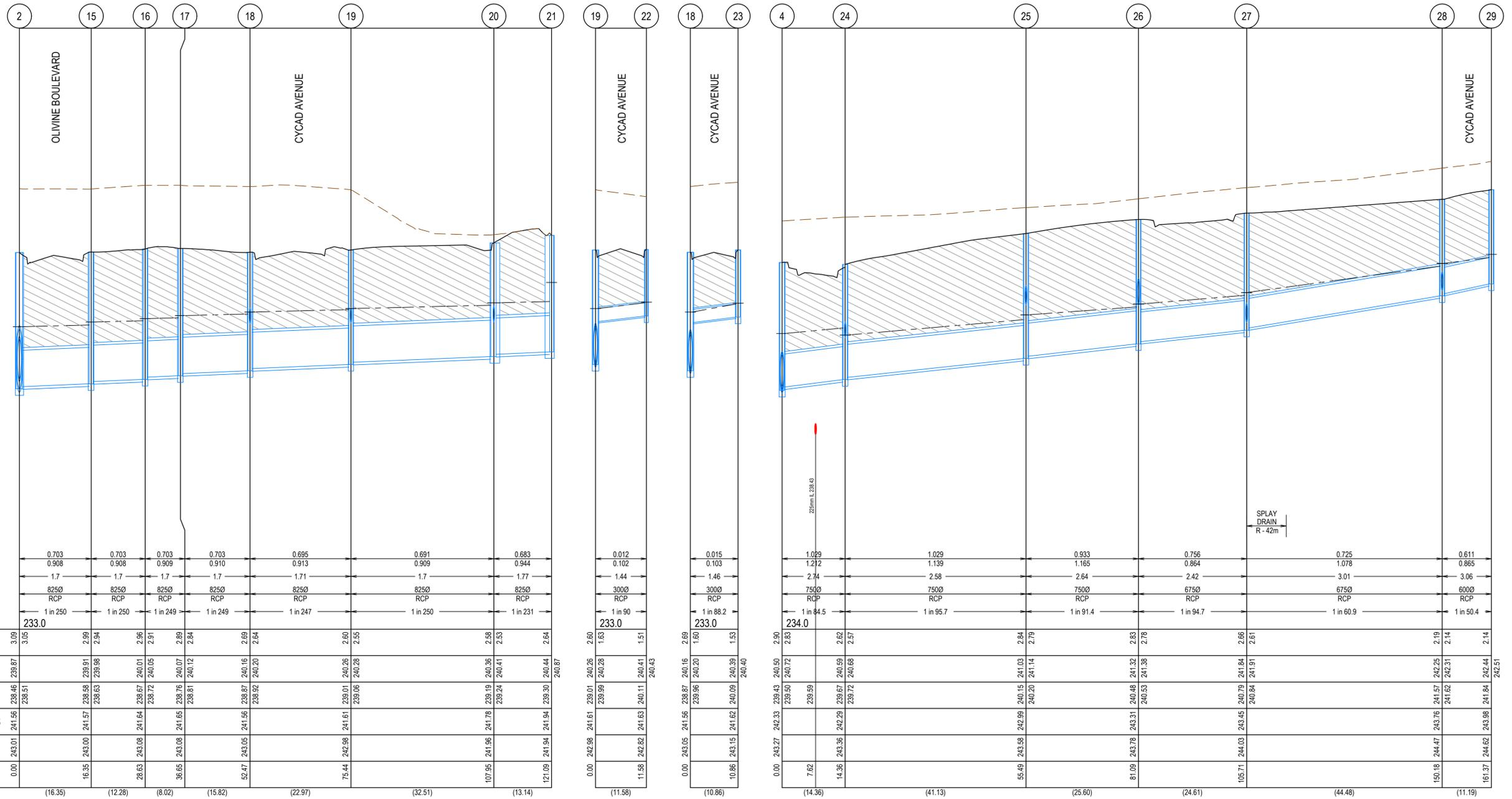

REV	DATE	AMENDMENT / REVISION DESCRIPTION	DESIGN	APPROVAL
0	05.10.18	ISSUED FOR CONSTRUCTION	PM/RB	AB

**ISSUED FOR CONSTRUCTION**

All setting out should be carried out in accordance with MPA/Council's standard drawings or as nominated on hard copy plans provided by SMEC. Any digital information supplied by this office is for information only. Any discrepancies should be discussed with the superintendent.

Quality Management - ISO 9001  
 OHS Management - AS/NZS 1880  
 Environmental Management - ISO 14001

Global-Mark.com.au®

TITLE	NAME
DRAFTER	R.Barua
DESIGNER	P.McKay
CHECKED	Z.Gosev
AUTHORISED	A.Burrows
SMEC DRAWING REF.	1700E-04
MELBOURNE WATER REF.	388/3079

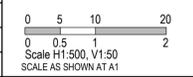

**SMEC**  
 Member of the Surbana Jurong Group  
 © ABN 47 065 475 149  
 Tower 4, Level 20, 727 Collins Street  
 Docklands, VIC 3008  
 Ph 03 9514 1500

**mirvac**

Olivine Estate - Stage 4  
 Whittlesea City Council  
 Road and Drainage  
 Drainage Longitudinal Sections - 2

MELWAYS REF <b>8 M2</b>	PROJECT / DRAWING No. <b>1700E-04-31</b>	SHEET No. <b>31 of 45</b>	REVISION <b>0</b>
----------------------------	---	------------------------------	----------------------

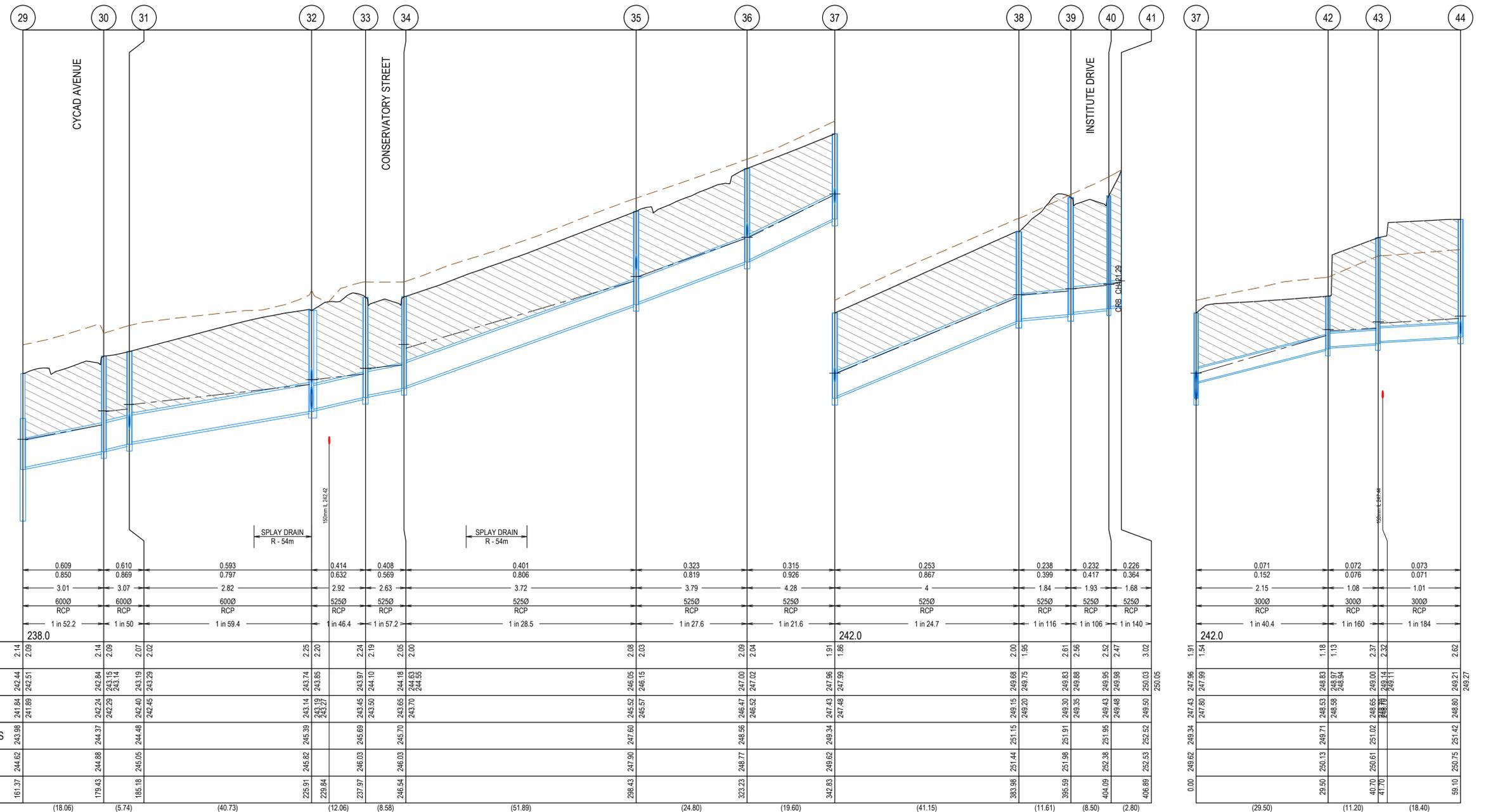

DESIGN FLOW (m3/s)	CAPACITY (m3/s)	AT GRADE VELOCITY (m/s)	NOMINAL PIPE SIZE (mm)	PIPE TYPE	GRADE	DATUM	DEPTH TO INVERT	HYDRAULIC GRADE LINE	INVERT LEVEL	FINISHED SURFACE LEVELS	EXISTING SURFACE LEVEL	CHAINAGE
0.609	0.850	3.01	6000	RCP	1 in 52.2	238.0	2.14	242.44	241.84	243.98	244.62	161.37
0.610	0.869	3.07	6000	RCP	1 in 50		2.09	242.84	242.24	244.88	245.05	179.43
0.593	0.797	2.82	6000	RCP	1 in 59.4		2.25	243.15	242.55	244.48	245.05	185.18
0.414	0.632	2.92	5250	RCP	1 in 46.4		2.20	243.85	243.25	244.48	245.05	225.91
0.408	0.569	2.63	5250	RCP	1 in 57.2		2.24	243.97	243.37	244.48	245.05	237.97
0.401	0.806	3.72	5250	RCP	1 in 28.5		2.05	244.18	243.58	244.48	245.05	246.54
0.323	0.819	3.79	5250	RCP	1 in 27.6		2.08	246.05	245.45	246.56	247.00	298.43
0.315	0.926	4.28	5250	RCP	1 in 21.6	242.0	2.04	247.02	246.42	247.00	247.00	323.23
0.253	0.867	4	5250	RCP	1 in 24.7		1.91	247.96	247.36	247.96	247.96	342.83
0.238	0.399	1.84	5250	RCP	1 in 116		1.86	249.99	249.39	249.99	249.99	383.98
0.232	0.417	1.93	5250	RCP	1 in 106		2.01	249.75	249.15	249.75	249.75	395.59
0.226	0.364	1.68	5250	RCP	1 in 140		3.02	250.03	249.43	249.75	249.75	404.09
0.071	0.152	2.15	3000	RCP	1 in 40.4	242.0	1.91	247.96	247.36	247.96	247.96	406.89
0.072	0.076	1.08	3000	RCP	1 in 160		1.54	247.99	247.39	247.99	247.99	406.89
0.073	0.071	1.01	3000	RCP	1 in 184		2.62	249.21	248.61	249.21	249.21	406.89

REV	DATE	AMENDMENT / REVISION DESCRIPTION	DESIGN	APPROVAL
0	05.10.18	ISSUED FOR CONSTRUCTION	PM/RB	AB

TITLE	NAME
DRAFTER	R.Barua
DESIGNER	P.McKay
CHECKED	Z.Gosev
AUTHORISED	A.Burrows
SMEC DRAWING REF.	1700E-04
MELBOURNE WATER REF.	388/3079

Member of the Surbana Jurong Group
   
 Tower 4, Level 20, 727 Collins Street
   
 Docklands, VIC 3008
   
 Ph 03 9514 1500

Olivine Estate - Stage 4  
 Whittlesea City Council  
 Road and Drainage  
 Drainage Longitudinal Sections - 3

MELWAYS REF 8 M2	PROJECT / DRAWING No. 1700E-04-32	SHEET No. 32 of 45	REVISION 0
---------------------	--------------------------------------	-----------------------	---------------



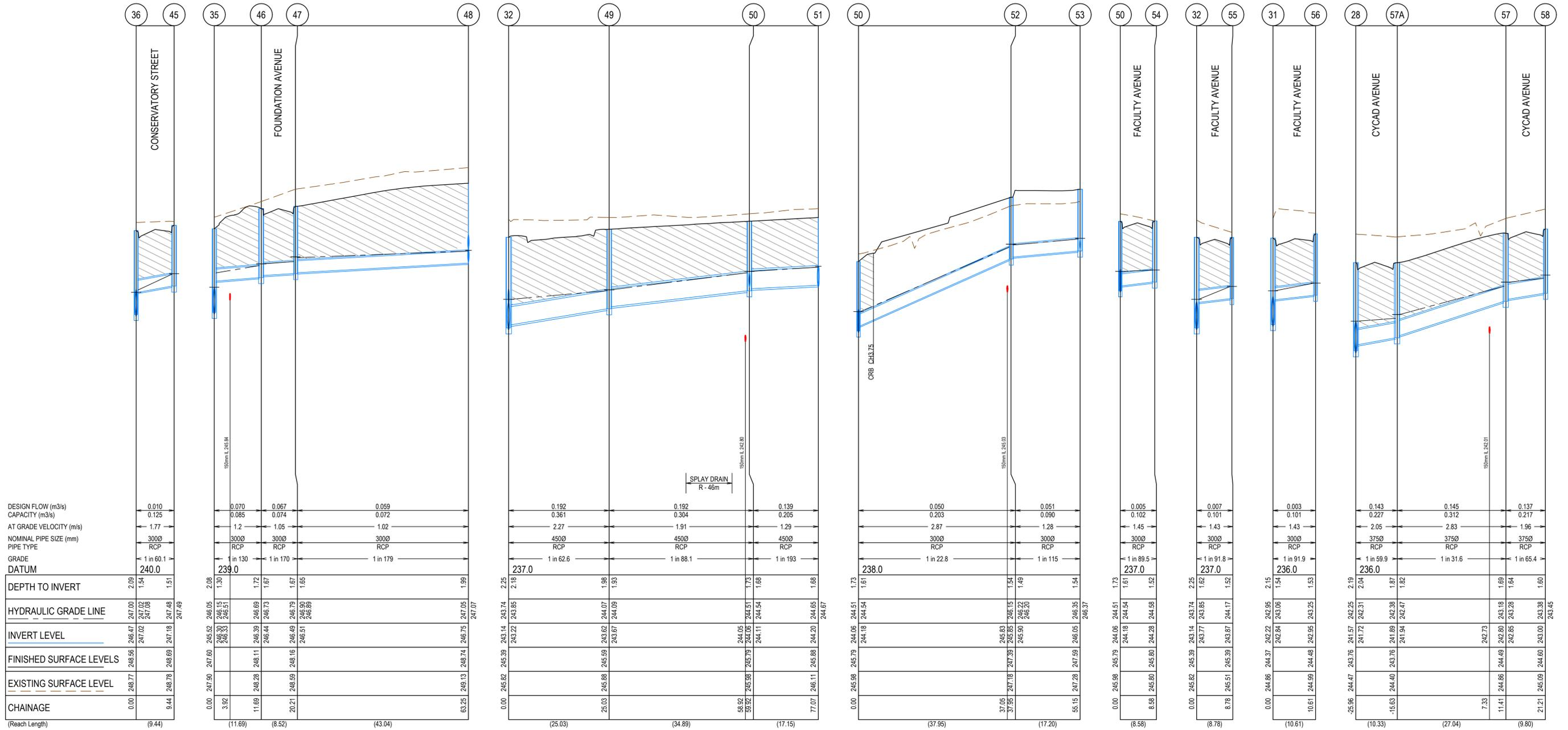

REV	DATE	AMENDMENT / REVISION DESCRIPTION	DESIGN	APPROVAL
0	05.10.18	ISSUED FOR CONSTRUCTION	PM/RB	AB

TITLE	NAME
DRAFTER	R.Barua
DESIGNER	P.McKay
CHECKED	Z.Gosev
AUTHORISED	A.Burrows
SMEC DRAWING REF.	1700E-04
MELBOURNE WATER REF.	388/3079

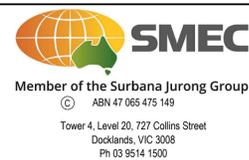
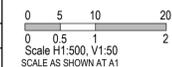

Olivine Estate - Stage 4  
Whittlesea City Council  
Road and Drainage  
Drainage Longitudinal Sections - 4

MELBOURNE REF	PROJECT / DRAWING No.	SHEET No.	REVISION
8 M2	1700E-04-33	33 of 45	0

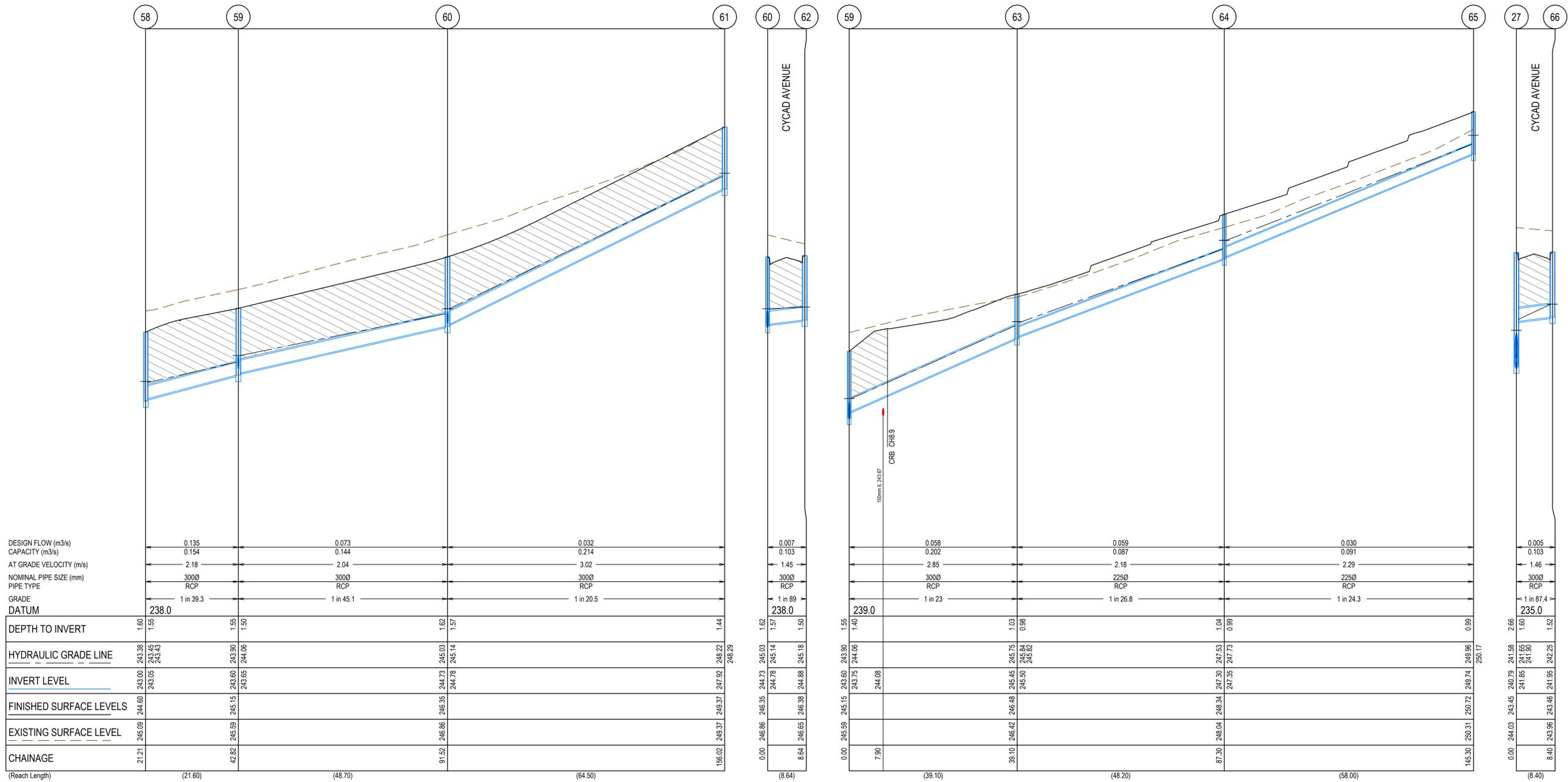

REV	DATE	AMENDMENT / REVISION DESCRIPTION	DESIGN	APPROVAL
0	05.10.18	ISSUED FOR CONSTRUCTION	PM/RB	AB

TITLE	NAME
DRAFTER	R.Barua
DESIGNER	P.McKay
CHECKED	Z.Gosev
AUTHORISED	A.Burrows
SMEC DRAWING REF.	1700E-04
MELBOURNE WATER REF.	388/3079

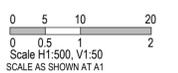

**SMEC**  
Member of the **Surbana Jurong Group**  
ABN 47 065 475 149  
Tower 4, Level 20, 727 Collins Street  
Docklands, VIC 3008  
Ph 03 9514 1500

**mirvac**

Olivine Estate - Stage 4  
Whittlesea City Council  
Road and Drainage  
Drainage Longitudinal Sections - 5

MELWAYS REF	PROJECT / DRAWING No.	SHEET No.	REVISION
8 M2	1700E-04-34	34 of 45	0

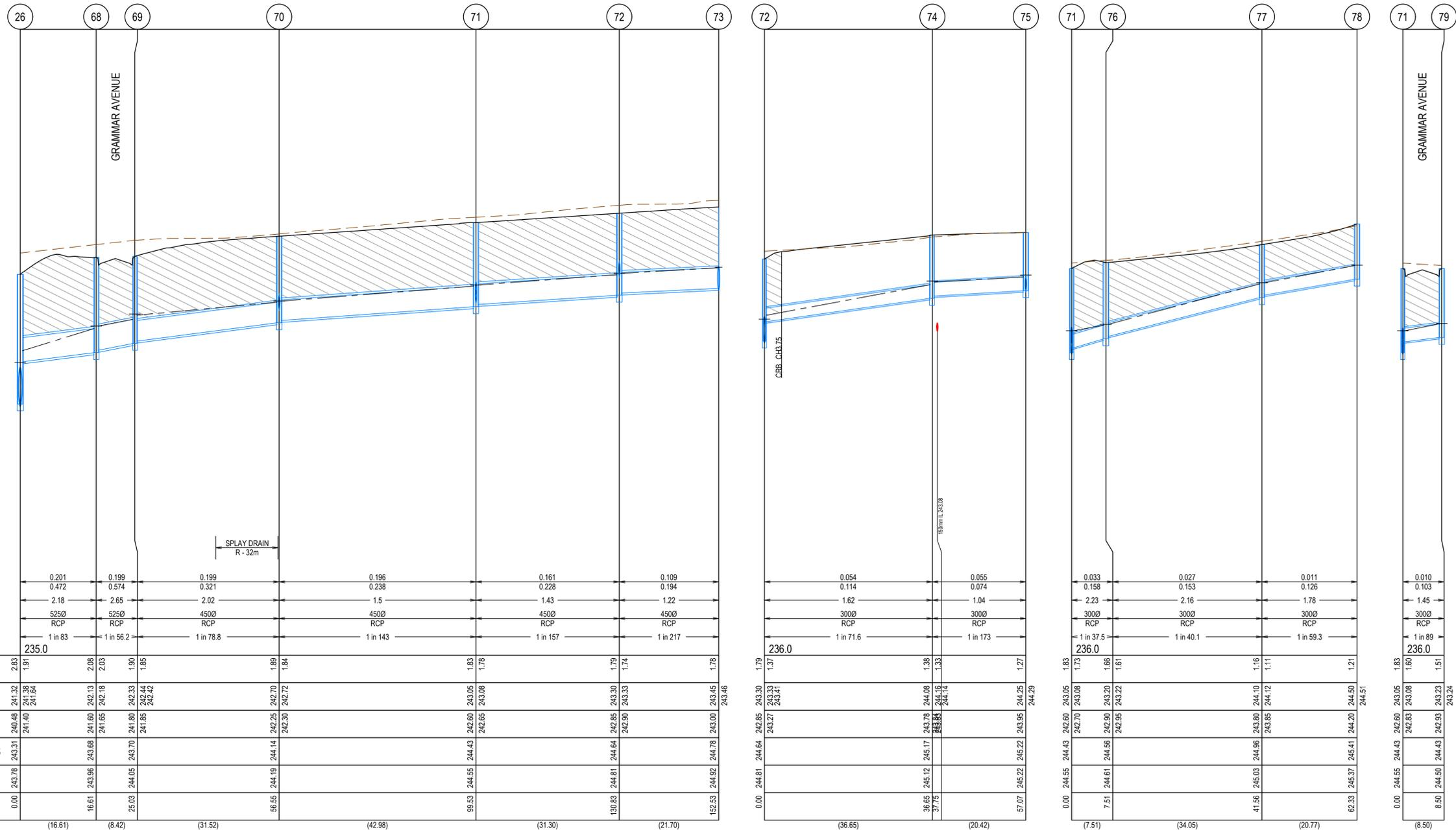

REV	DATE	AMENDMENT / REVISION DESCRIPTION	DES/DT	APPROVAL
0	05.10.18	ISSUED FOR CONSTRUCTION	PM/RB	AB

TITLE	NAME
DRAFTER	R.Barua
DESIGNER	P.McKay
CHECKED	Z.Gosev
AUTHORISED	A.Burrows
SMEC DRAWING REF.	1700E-04
MELBOURNE WATER REF.	388/3079

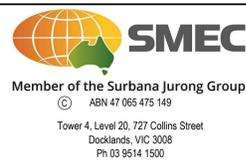
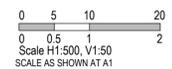

Olivine Estate - Stage 4  
Whittlesea City Council  
Road and Drainage  
Drainage Longitudinal Sections - 6

MELWAYS REF	PROJECT / DRAWING No.	SHEET No.	REVISION
8 M2	1700E-04-35	35 of 45	0

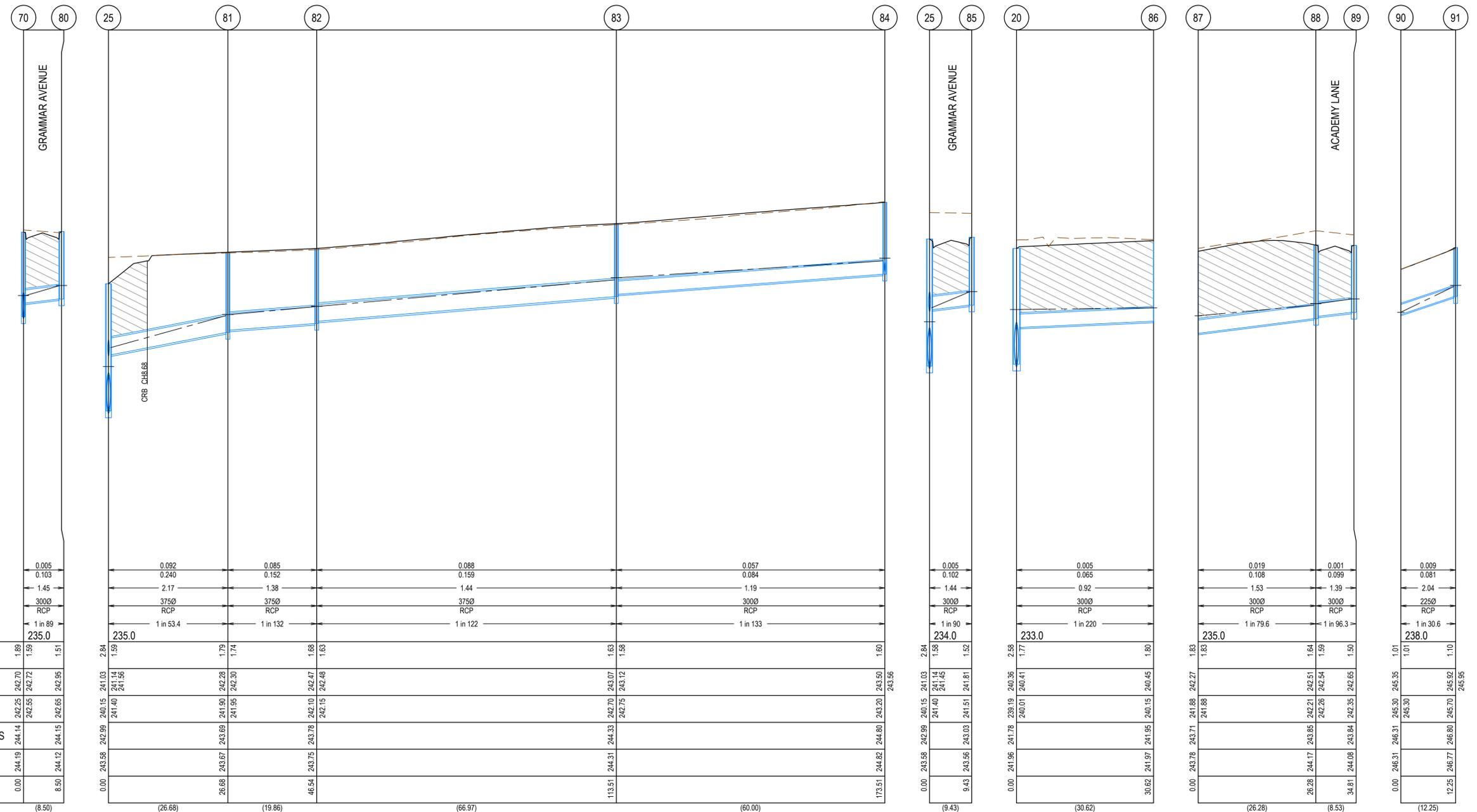

DESIGN FLOW (m3/s)	0.005
CAPACITY (m3/s)	0.103
AT GRADE VELOCITY (m/s)	1.45
NOMINAL PIPE SIZE (mm)	3000
PIPE TYPE	RCP
GRADE	1 in 89
DATUM	235.0
DEPTH TO INVERT	0.00
HYDRAULIC GRADE LINE	242.25
INVERT LEVEL	242.55
FINISHED SURFACE LEVELS	244.19
EXISTING SURFACE LEVEL	244.12
CHAINAGE	0.00

(Reach Length) (8.50)

DESIGN FLOW (m3/s)	0.092	0.085	0.088	0.057
CAPACITY (m3/s)	0.240	0.152	0.159	0.084
AT GRADE VELOCITY (m/s)	2.17	1.38	1.44	1.19
NOMINAL PIPE SIZE (mm)	3750	3750	3750	3000
PIPE TYPE	RCP	RCP	RCP	RCP
GRADE	1 in 53.4	1 in 132	1 in 122	1 in 133
DATUM	235.0			
DEPTH TO INVERT	240.15	241.03	241.03	241.03
HYDRAULIC GRADE LINE	241.40	241.14	243.07	243.56
INVERT LEVEL	241.56	242.28	243.12	243.56
FINISHED SURFACE LEVELS	243.58	243.69	244.33	244.80
EXISTING SURFACE LEVEL	243.58	243.67	244.31	244.82
CHAINAGE	0.00	26.66	46.54	113.51

(Reach Length) (26.68) (19.86) (66.97) (60.00)

DESIGN FLOW (m3/s)	0.005	0.005	0.019	0.001	0.009
CAPACITY (m3/s)	0.102	0.065	0.108	0.099	0.081
AT GRADE VELOCITY (m/s)	1.44	0.92	1.53	1.39	2.04
NOMINAL PIPE SIZE (mm)	3000	3000	3000	3000	2250
PIPE TYPE	RCP	RCP	RCP	RCP	RCP
GRADE	1 in 90	1 in 220	1 in 79.6	1 in 96.3	1 in 30.6
DATUM	234.0	233.0	235.0	238.0	
DEPTH TO INVERT	240.15	240.36	241.88	242.65	245.35
HYDRAULIC GRADE LINE	241.40	240.41	242.27	243.84	245.30
INVERT LEVEL	241.45	240.41	241.88	242.35	245.30
FINISHED SURFACE LEVELS	243.03	241.78	243.71	246.00	246.77
EXISTING SURFACE LEVEL	243.03	241.78	243.71	246.00	246.77
CHAINAGE	0.00	30.62	0.00	26.28	12.25

(Reach Length) (9.43) (30.62) (26.28) (8.53) (12.25)

REV	DATE	AMENDMENT / REVISION DESCRIPTION	DESIGN	APPROVAL
0	05.10.18	ISSUED FOR CONSTRUCTION	PM/RB	AB

**ISSUED FOR CONSTRUCTION**

All setting out should be carried out in accordance with MPA/Council's standard drawings or as nominated on hard copy plans provided by SMEC. Any digital information supplied by this office is for information only. Any discrepancies should be discussed with the superintendent.		TITLE	NAME
Quality Management - ISO 9001	Drift Management - AS/NZS 1801	DRAFTER	R.Barua
Environmental Management - ISO 14001		DESIGNER	P.McKay
		CHECKED	Z.Gosev
		AUTHORISED	A.Burrows
		SMEC DRAWING REF.	1700E-04
		MELBOURNE WATER REF.	388/3079

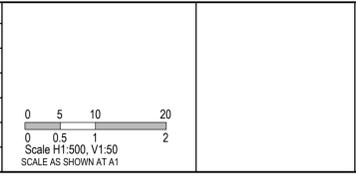

**SMEC**  
Member of the Surlana Jurong Group  
ABN 47 065 475 149  
Tower 4, Level 20, 727 Collins Street  
Docklands, VIC 3008  
Ph 03 9514 1500

**mirvac**

Olivine Estate - Stage 4  
Whittlesea City Council  
Road and Drainage  
Drainage Longitudinal Sections - 7

MELWAYS REF 8 M2	PROJECT / DRAWING No. 1700E-04-36	SHEET No. 36 of 45	REVISION 0
---------------------	--------------------------------------	-----------------------	---------------

NAME	PIT TYPE	INTERNAL WD	LEN	INLET DIA	INV LEV	OUTLET DIA	INV LEV	PIT SETOUT RL	DEPTH	STD DWG	REMARKS
1	ENDPIPE			1350	238.45			241.53	0.00		CONNECT TO EXISTING
2	JUNCTION PIT	1500	1350	825	238.87	1350	238.46	241.54	3.08	EDCM 607	HAUNCH PIT. COVER 600x900
				825	238.51						
3	GRATED JUNCTION PIT	1050	900	825	239.28	825	239.23	242.06	2.82	EDCM 607	1050x900 HD COVER. PROVIDE GATIC GULLY GRATE (ROAD V-TYPE) 33IV964 OR SIMILAR
4	JUNCTION PIT	1050	1050	750	239.50	825	239.43	242.33	2.91	EDCM 607	HAUNCH PIT. COVER 600x900
				750	239.50						
5	DOUBLE GRATED ENTRY PIT	900	900	750	240.10	750	240.05	242.68	2.63	EDCM 607 & 602	HAUNCH PIT. COVER 600x900
				300	240.80						
6	GRATED ENTRY PIT	900	900	750	240.46	750	240.41	243.12	2.71	EDCM 607 & 601	HAUNCH PIT. COVER 600x900
				300	241.47						
7	GRATED ENTRY PIT	900	900	750	240.75	750	240.70	243.62	2.92	EDCM 607 & 601	HAUNCH PIT. COVER 600x900
				300	241.98						
8	GRATED ENTRY PIT	900	900	750	240.96	750	240.91	243.92	3.01	EDCM 607 & 601	HAUNCH PIT. COVER 600x900
				300	242.27						
9	ENDPIPE			750	241.13	750	241.12	244.29	3.17		BLANK OFF ENDPIPE
10	GRATED ENTRY PIT	600	900			300	242.41	243.91	1.50	EDCM 605 & 601	
11	GRATED ENTRY PIT	600	900			300	242.11	243.61	1.50	EDCM 605 & 601	
12	GRATED ENTRY PIT	600	900			300	241.61	243.11	1.50	EDCM 605 & 601	
13	DOUBLE GRATED ENTRY PIT	600	900			300	241.03	242.64	1.61	EDCM 605 & 602	
24	DOUBLE GRATED ENTRY PIT	1050	900	300	240.65	750	239.67	242.22	2.55	EDCM 607 & 602	HAUNCH PIT. COVER 600x900
				750	239.72						
14	GRATED ENTRY PIT	600	900			300	240.81	242.34	1.53	EDCM 605 & 601	
15	GRATED ENTRY PIT	1200	900	825	238.63	825	238.58	241.57	2.99	EDCM 607 & 601	HAUNCH PIT. COVER 600x900
16	GRATED ENTRY PIT	1200	900	825	238.73	825	238.68	241.64	2.96	EDCM 607 & 601	HAUNCH PIT. COVER 600x900
17	GRATED ENTRY PIT	1200	900	825	238.81	825	238.76	241.65	2.89	EDCM 607 & 601	HAUNCH PIT. COVER 600x900
18	DOUBLE GRATED ENTRY PIT	1200	900	825	238.92	825	238.87	241.56	2.69	EDCM 607 & 602	HAUNCH PIT UNDER KERB. COVER 600x900
				300	239.97						
19	GRATED ENTRY PIT	1200	900	825	239.06	825	239.01	241.61	2.60	EDCM 607 & 601	HAUNCH PIT UNDER KERB. COVER 600x900
				300	239.99						
20	GRATED ENTRY PIT	1050	1350	825	239.24	825	239.19	241.78	2.58	EDCM 607 & 601	HAUNCH PIT UNDER KERB. COVER 600x900
				300	240.01						
21	GRATED PIT	1050	900			825	239.30	242.12	2.82	EDCM 605	1050x900 HD COVER. PROVIDE GATIC GULLY GRATE (ROAD V-TYPE) 33IV964 OR SIMILAR
22	GRATED ENTRY PIT	600	900			300	240.11	241.62	1.51	EDCM 605 & 601	
23	DOUBLE GRATED ENTRY PIT	600	900			300	240.09	241.62	1.53	EDCM 605 & 602	
25	GRATED ENTRY PIT	1050	900	750	240.20	750	240.15	242.99	2.84	EDCM 607 & 601	HAUNCH PIT. COVER 600x900
				375	241.40						
				300	241.40						
26	GRATED ENTRY PIT	1050	900	675	240.53	750	240.48	243.31	2.83	EDCM 607 & 601	HAUNCH PIT. COVER 600x900
				525	241.40						
27	GRATED ENTRY PIT	900	900	675	240.84	675	240.79	243.45	2.66	EDCM 607 & 601	HAUNCH PIT UNDER KERB. COVER 600x900
				300	241.85						
28	GRATED ENTRY PIT	900	900	600	241.34	675	241.57	243.76	2.19	EDCM 607 & 601	HAUNCH PIT UNDER KERB. COVER 600x900
				375	241.72						
29	GRATED ENTRY PIT	900	900	600	241.84	600	241.84	243.98	2.14	EDCM 607 & 601	HAUNCH PIT UNDER KERB. COVER 600x900
30	DOUBLE GRATED ENTRY PIT	750	900	600	242.29	600	242.24	244.37	2.14	EDCM 607 & 602	HAUNCH PIT. COVER 600x900
31	GRATED ENTRY PIT	900	900	600	242.45	600	242.40	244.48	2.07	EDCM 607 & 602	HAUNCH PIT. COVER 600x900
				300	242.77						
32	GRATED ENTRY PIT	900	1050	525	243.19	600	243.14	245.39	2.25	EDCM 607 & 601	HAUNCH PIT. COVER 1050x900
				450	243.22						
				300	243.77						
33	GRATED ENTRY PIT	600	900	525	243.50	525	243.45	245.69	2.24	EDCM 605	
34	DOUBLE GRATED ENTRY PIT	750	900	525	243.70	525	243.65	245.70	2.05	EDCM 607 & 602	HAUNCH PIT. COVER 600x900
35	GRATED ENTRY PIT	750	900	525	245.57	525	245.52	247.60	2.08	EDCM 607 & 601	HAUNCH PIT. COVER 600x900
				300	246.15						
36	GRATED ENTRY PIT	750	900	525	246.52	525	246.47	248.56	2.09	EDCM 607 & 601	HAUNCH PIT. COVER 600x900
				300	247.02						
37	GRATED ENTRY PIT	750	900	525	247.48	525	247.43	249.34	1.91	EDCM 607 & 601	HAUNCH PIT. COVER 600x900
				300	247.80						
38	GRATED ENTRY PIT	900	900	525	249.20	525	249.15	251.15	2.00	EDCM 607 & 601	HAUNCH PIT. COVER 600x900
39	GRATED ENTRY PIT	600	900	525	249.35	525	249.30	251.91	2.61	EDCM 605 & 601	
40	GRATED ENTRY PIT	600	900	525	249.48	525	249.43	251.95	2.52	EDCM 605 & 601	
41	ENDPIPE			525	249.50	525	249.50	252.52	3.02		BLANK OFF ENDPIPE

NAME	PIT TYPE	INTERNAL WD	LEN	INLET DIA	INV LEV	OUTLET DIA	INV LEV	PIT SETOUT RL	DEPTH	STD DWG	REMARKS
42	JUNCTION PIT	600	900	300	248.58	300	248.53	249.81	1.28	EDCM 605	
43	JUNCTION PIT	600	900	300	248.70	300	248.65	251.02	2.37	EDCM 605	
44	GRATED PIT	600	900	300	248.85	300	248.80	250.75	1.95	EDCM 605	600x900 HD COVER. PROVIDE GATIC GULLY GRATE (ROAD V-TYPE) 33IV964 OR SIMILAR
45	GRATED ENTRY PIT	600	900			300	247.18	248.69	1.51	EDCM 605 & 601	
46	GRATED ENTRY PIT	600	900	300	246.40	300	246.35	248.12	1.77	EDCM 605 & 601	
47	DOUBLE GRATED ENTRY PIT	600	900	300	246.51	300	246.49	248.16	1.67	EDCM 605 & 602	
48	ENDPIPE			300	246.80	300	246.75	248.67	1.92		BLANK OFF ENDPIPE
				300	247.12						
49	GRATED ENTRY PIT	600	900	450	243.67	450	243.62	245.59	1.98	EDCM 605 & 601	
50	GRATED ENTRY PIT	600	900	450	244.11	450	244.06	245.79	1.73	EDCM 605 & 601	
				300	244.18						
				300	244.18						
51	ENDPIPE			450	244.20	450	244.20	245.82	1.62		BLANK OFF ENDPIPE
52	JUNCTION PIT	600	900	300	245.90	300	245.85	247.39	1.54	EDCM 605	
53	GRATED PIT	600	900	225	246.10	300	246.05	247.29	1.24	EDCM 605	600x900 HD COVER. PROVIDE GATIC GULLY GRATE (ROAD V-TYPE) 33IV964 OR SIMILAR
54	GRATED ENTRY PIT	600	900			300	244.28	245.79	1.51	EDCM 605 & 601	
55	GRATED ENTRY PIT	600	900			300	243.87	245.39	1.52	EDCM 605 & 601	
56	GRATED ENTRY PIT	600	900			300	242.86	244.48	1.62	EDCM 605 & 601	
57A	DOUBLE GRATED ENTRY PIT	600	900	375	241.94	375	241.89	243.76	1.87	EDCM 605 & 602	
57	GRATED ENTRY PIT	600	900	375	242.85	375	242.80	244.49	1.69	EDCM 605 & 601	
58	GRATED ENTRY PIT	600	900	300	243.05	375	243.00	244.60	1.60	EDCM 605 & 601	
59	GRATED ENTRY PIT	600	900	300	243.65	300	243.60	245.15	1.55	EDCM 605 & 601	
				300	243.75						
60	GRATED ENTRY PIT	600	900	300	244.78	300	244.73	246.35	1.62	EDCM 605 & 601	
				300	244.78						
61	GRATED ENTRY PIT	600	900			300	247.92	249.37	1.44	EDCM 605 & 601	
62	GRATED ENTRY PIT	600	900			300	244.88	246.38	1.50	EDCM 605 & 601	
63	JUNCTION PIT	600	900	225	245.50	300	245.45	246.48	1.03	EDCM 605	
64	JUNCTION PIT	600	900	225	247.35	225	247.30	248.34	1.04	EDCM 605	
65	JUNCTION PIT	600	900	225	249.74	225	249.74	250.72	0.99	EDCM 605	
66	GRATED ENTRY PIT	600	900			300	241.95	243.46	1.52	EDCM 605 & 601	
68	GRATED ENTRY PIT	750	900	525	241.65	525	241.60	243.68	2.08	EDCM 607 & 601	HAUNCH PIT UNDER KERB. COVER 600x900
69	GRATED ENTRY PIT	600	900	450	241.85	525	241.80	243.70	1.90	EDCM 605 & 601	
70	GRATED ENTRY PIT	600	900	450	242.30	450	242.25	244.17	1.92	EDCM 605 & 601	
				300	242.55						
71	GRATED ENTRY PIT	600	900	450	242.65	450	242.60	244.44	1.84	EDCM 605 & 601	
				300	242.70						
				300	242.83						
72	GRATED ENTRY PIT	600	900	450	242.90	450	242.85	244.64	1.79	EDCM 605 & 601	
				300	243.04						
73	ENDPIPE			450	243.00	450	243.00	244.77	1.77		BLANK



FOR CONTINUATION REFER TO SHEET 1700E-04-39

REV	DATE	AMENDMENT / REVISION DESCRIPTION	DESIGN	APPROVAL
0	05.10.18	ISSUED FOR CONSTRUCTION	PM/RB	AB

**ISSUED FOR CONSTRUCTION**

All setting out should be carried out in accordance with MPA/Council's standard drawings or as nominated on hard copy plans provided by SMEC. Any digital information supplied by this office is for information only. Any discrepancies should be discussed with the superintendent.

TITLE	NAME
DRAFTER	R.Barua
DESIGNER	P.McKay
CHECKED	Z.Gosev
AUTHORISED	A.Burrows
SMEC DRAWING REF.	1700E-04
MELBOURNE WATER REF.	388/3079

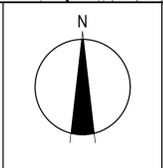
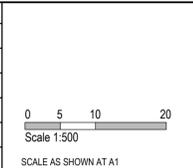

**SMEC**  
Member of the Surlana Jurong Group  
© ABN 47 065 475 149  
Tower 4, Level 20, 727 Collins Street  
Docklands, VIC 3008  
Ph 03 9514 1500



Olivine Estate - Stage 4 Whittlesea City Council Road and Drainage Signage & Linemarking Plan - 1		MELWAYS REF 8 M2	PROJECT / DRAWING No. 1700E-04-38	SHEET No. 38 of 45	REVISION 0
--	--	---------------------	--------------------------------------	-----------------------	---------------

FOR CONTINUATION REFER TO SHEET 1700E-04-38

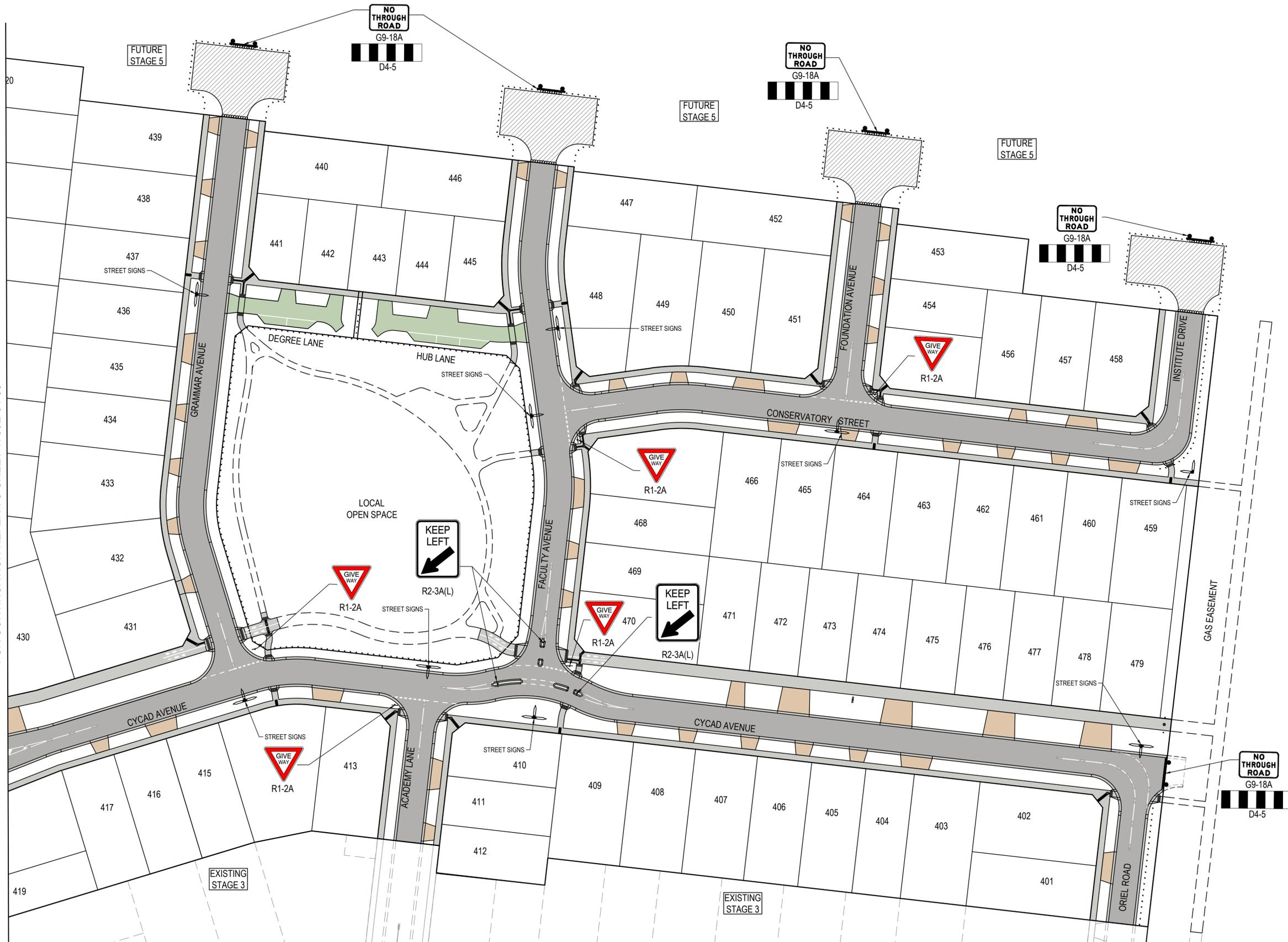

REV	DATE	AMENDMENT / REVISION DESCRIPTION	DESIGN	APPROVAL
0	05.10.18	ISSUED FOR CONSTRUCTION	PM/RB	AB

All setting out should be carried out in accordance with MPA/Council's standard drawings or as nominated on hard copy plans provided by SMEC. Any digital information supplied by this office is for information only. Any discrepancies should be discussed with the superintendent.

TITLE	NAME
DRAFTER	R.Barua
DESIGNER	P.McKay
CHECKED	Z.Gosev
AUTHORISED	A.Burrows
SMEC DRAWING REF.	1700E-04
MELBOURNE WATER REF.	388/3079

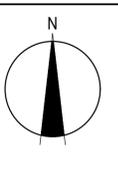
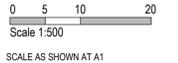

**SMEC**  
Member of the Surlana Jurong Group  
© ABN 47 065 475 149  
Tower 4, Level 20, 727 Collins Street  
Docklands, VIC 3008  
Ph 03 9514 1500



Olivine Estate - Stage 4  
Whittlesea City Council  
Road and Drainage  
Signage & Linemarking Plan - 2

MELWAYS REF 8 M2	PROJECT / DRAWING No. 1700E-04-39	SHEET No. 39 of 45	REVISION 0
---------------------	--------------------------------------	-----------------------	---------------

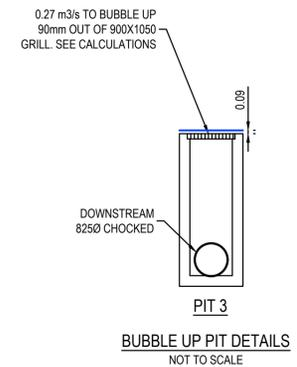
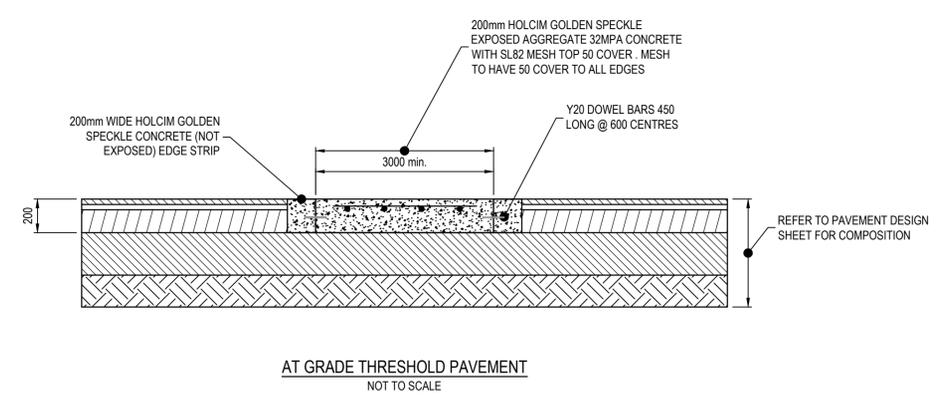
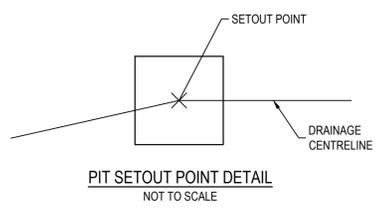
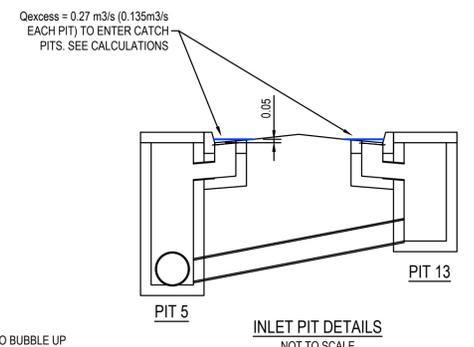
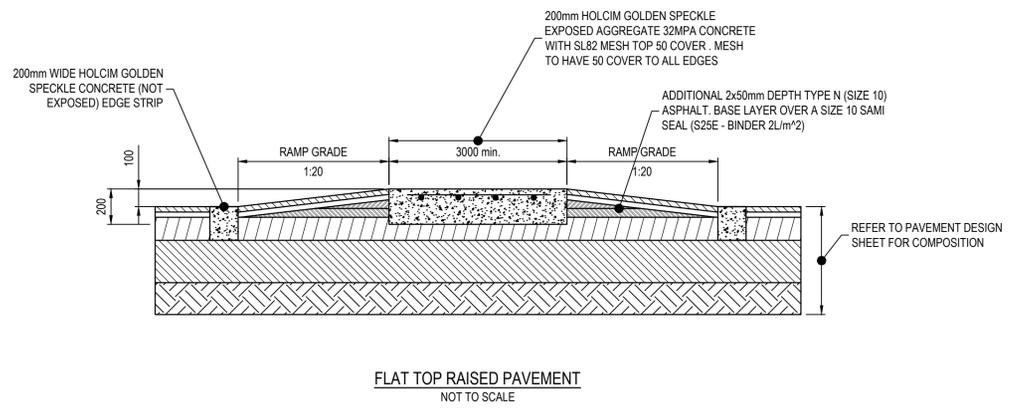
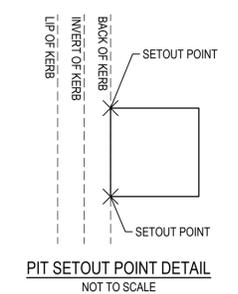
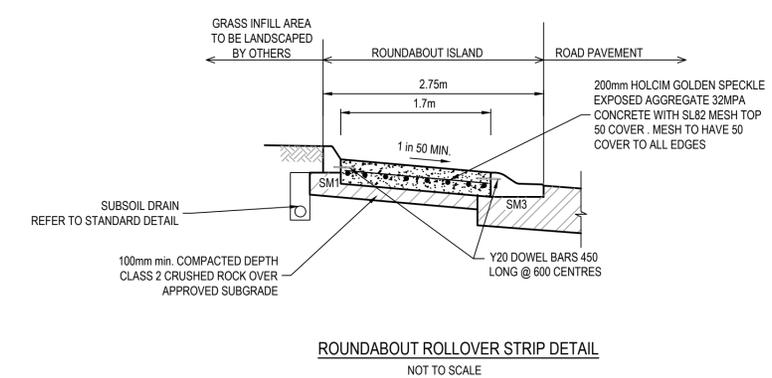
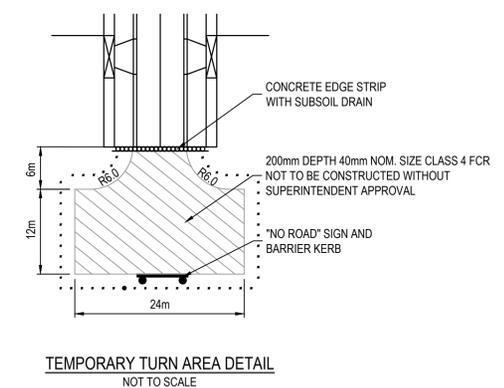
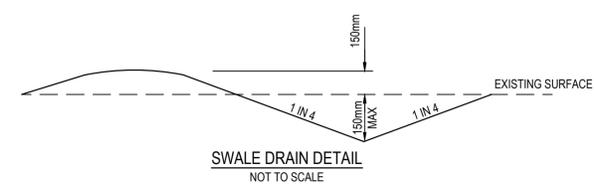
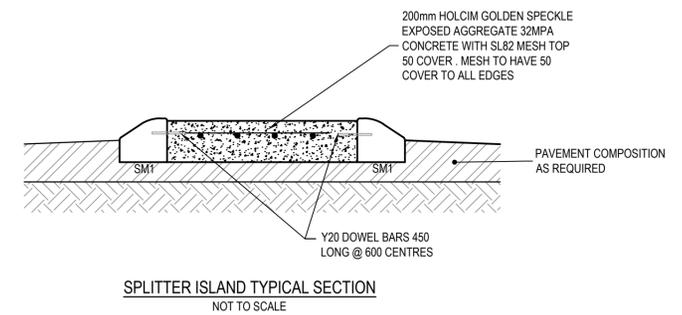
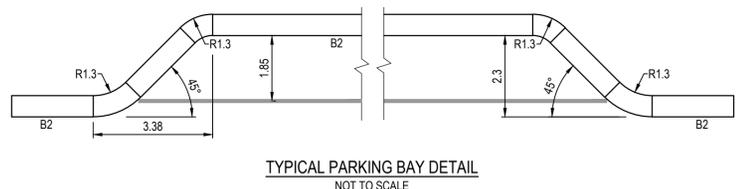
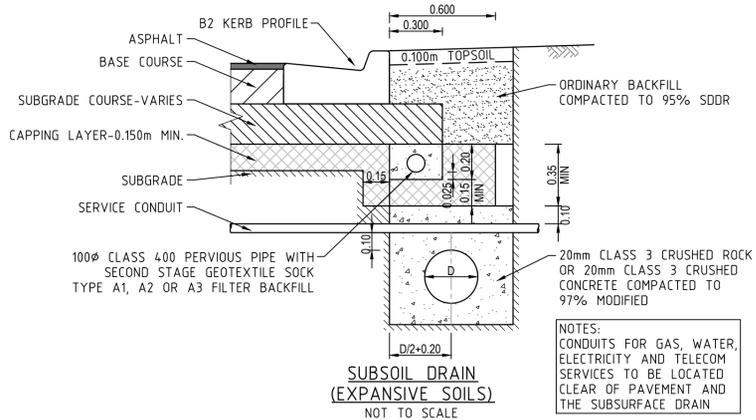

**WARNING**  
**BEWARE OF UNDERGROUND SERVICES**  
The locations of underground services are approximate only and their exact position should be proven on site. No guarantee is given that all existing services are shown. Locate all underground services before commencement of works. **DIAL 1100 BEFORE YOU DIG**  
[www.1100.com.au](http://www.1100.com.au)

REV	DATE	AMENDMENT / REVISION DESCRIPTION	DESIGN	APPROVAL
0	05.10.18	ISSUED FOR CONSTRUCTION	PM/RB	AB

**ISSUED FOR CONSTRUCTION**

All setting out should be carried out in accordance with MPA/Council's standard drawings or as nominated on hard copy plans provided by SMEC. Any digital information supplied by this office is for information only. Any discrepancies should be discussed with the superintendent.		TITLE	NAME
DRAFTER	R.Barua	CHECKED	Z.Gosev
DESIGNER	P.McKay	AUTHORISED	A.Burrows
SMEC DRAWING REF.	1700E-04	MELBOURNE WATER REF.	388/3079

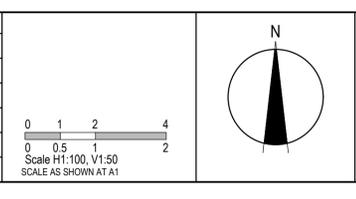

**SMEC**  
Member of the **Surbana Jurong Group**  
ABN 47 065 475 149  
Tower 4, Level 20, 727 Collins Street  
Docklands, VIC 3008  
Ph 03 9514 1500

**mirvac**

Olivine Estate - Stage 4 Whittlesea City Council Road and Drainage General Notes & Details		MELWAYS REF <b>8 M2</b>	PROJECT / DRAWING No. <b>1700E-04-40</b>	SHEET No. <b>40 of 45</b>	REVISION <b>0</b>
---	--	----------------------------	---	------------------------------	----------------------



**OLIVINE BOULEVARD  
PAVEMENT COMPOSITION**

670mm DEPTH PAVEMENT COMPOSITION		
PAVEMENT LAYER	LAYER THICKNESS (mm)	MATERIAL
A WEARING COURSE	40	SIZE 10 TYPE N ASPHALT (CLASS 170 BINDER)
B INTERMEDIATE COURSE 1	40	SIZE 10 TYPE N ASPHALT (CLASS 170 BINDER)
C INTERMEDIATE COURSE 2	-	-
D SAMII SEAL	10	SIZE 10 S18RF
E PRIME	YES	
F BASE COURSE	110	SIZE 20 CLASS 2 CRUSHED ROCK, COMPACTED TO A MINIMUM DENSITY RATIO OF 98% (MODIFIED) AS1289.5.2.1
G UPPER BASE COURSE	70	CLASS 3 CRUSHED ROCK COMPACTED TO A MINIMUM DENSITY RATIO OF 98% (MODIFIED) AS1289.5.2.1
H LOWER SUBBASE	100	CLASS 4 CRUSHED ROCK COMPACTED TO A MINIMUM DENSITY RATIO OF 98% (MODIFIED) AS1289.5.2.1. THE LOWER SUBBASE LAYER MAY BE ELIMINATED AND REPLACED WITH A SINGLE UPPER SUBBASE LAYER 170mm IN THICKNESS
I CAPPING LAYER	300	IMPORTED TYPE A FILL WITH CBR <sub>28%</sub> SWELL <sub>1.5%</sub> PERMEABILITY k <sub>s</sub> ≤5x10 <sup>-6</sup> m/s. OR LIME STABILISED SITE WON CLAY WHICH CONFORMS TO THE PARAMETERS ABOVE.
J SUBGRADE		CBR 1.5% EXPANSIVE

**CYCAD AVENUE, GRAMMAR AVENUE, FACULTY AVE, FOUNDATION AVENUE, CONSERVATORY STREET, INSTITUE DRIVE, OREIL ROAD AND ACADEMY LANE PAVEMENT COMPOSITION**

595mm DEPTH PAVEMENT COMPOSITION		
PAVEMENT LAYER	LAYER THICKNESS (mm)	MATERIAL
A WEARING COURSE	30	SIZE 10 TYPE N ASPHALT (CLASS 170 BINDER)
B INTERMEDIATE COURSE 1	30	SIZE 10 TYPE N ASPHALT (CLASS 170 BINDER)
C INTERMEDIATE COURSE 2	-	-
D SAMII SEAL	10	SIZE 10 S18RF
E PRIME	YES	
F BASE COURSE	130	SIZE 20 CLASS 2 CRUSHED ROCK COMPACTED TO A MINIMUM DRY DENSITY RATIO OF 98% (MODIFIED) AS1289.5.2.1
G UPPER BASE COURSE	-	-
H LOWER BASE	110	CLASS 4 CRUSHED ROCK COMPACTED TO A MINIMUM DRY DENSITY RATIO OF 98% (MODIFIED) AS1289.5.2.1
I CAPPING LAYER	285	IMPORTED TYPE A FILL WITH CBR <sub>28%</sub> SWELL <sub>1.5%</sub> PERMEABILITY k <sub>s</sub> ≤5x10 <sup>-6</sup> m/s. OR LIME STABILISED SITE WON CLAY WHICH CONFORMS TO THE PARAMETERS ABOVE.
J SUBGRADE		SUBGRADE CLAY AS FOUND (C.B.R = 2%) (IF REQUIRED, SUBGRADE IMPROVEMENT WORKS TO BE UNDERTAKEN TO COUNCIL'S SATISFACTION)

**MEWS COMPOSITION - EDCM503**

300mm DEPTH PAVEMENT COMPOSITION		
PAVEMENT LAYER	LAYER THICKNESS (mm)	MATERIAL
CONCRETE	200	N25 CONCRETE WITH S182 MESH TOP 50 COVER. MESH TO HAVE 50 COVER TO ALL EDGES.
SUB BASE	100	CLASS 3 CRUSHED ROCK OR CLASS 3 CRUSHED CONCRETE MECHANICALLY COMPACTED

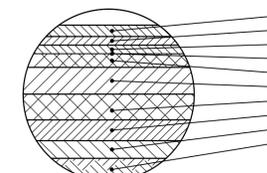

**PAVEMENT COMPOSITION  
KEY DIAGRAM**

**WARNING**  
**BEWARE OF UNDERGROUND SERVICES**  
The locations of underground services are approximate only and their exact position should be proven on site.  
No guarantee is given that all existing services are shown.  
Locate all underground services before commencement of works  
**DIAL 1100 BEFORE YOU DIG**  
www.1100.com.au

REV	DATE	AMENDMENT / REVISION DESCRIPTION	DES/DT	APPROVAL
0	05.10.18	ISSUED FOR CONSTRUCTION	PM/RB	AB

**ISSUED FOR CONSTRUCTION**

TITLE	NAME
DRAFTER	R.Barua
DESIGNER	P.McKay
CHECKED	Z.Gosev
AUTHORISED	A.Burrows
SMEC DRAWING REF.	1700E-04
MELBOURNE WATER REF.	388/3079

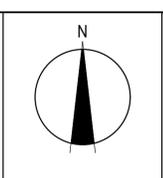
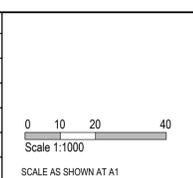

**SMEC**  
Member of the **Surbana Jurong Group**  
ABN 47 065 475 149  
Tower 4, Level 20, 727 Collins Street  
Docklands, VIC 3008  
Ph 03 9514 1500

**mirvac**

Olivine Estate - Stage 4 Whittlesea City Council Road and Drainage Pavement Details		MELBAYS REF <b>8 M2</b>	PROJECT / DRAWING No. <b>1700E-04-41</b>	SHEET No. <b>41 of 45</b>	REVISION <b>0</b>
--	--	----------------------------	---	------------------------------	----------------------

- JOINT DETAIL NOTES:**
1. SAW JOINTS ARE TO BE PLACED AT A MAXIMUM 5m SPACING AT INTERSECTIONS AND CONSTRUCTED 18-24 HOURS AFTER POURING.
  2. TRANSVERSE/CONTRACTION JOINTS ARE TO BE PLACED AT A MAXIMUM SPACING OF 12m.
  3. ISOLATION JOINTS ARE TO BE PLACED AROUND PITS.
  4. ALL JOINTS SHALL BE LOCATED AND SPACED IN ACCORDANCE WITH "CEMENT AND CONCRETE ASSOCIATION OF AUSTRALIA - CONCRETE PAVEMENT DESIGN FOR RESIDENTIAL STREETS 1997".

**NOTE:**  
CONCRETE SHALL BE CURED IN ACCORDANCE WITH AS3600 AND NOT TO BE TRAFFICKED UNTIL AT LEAST SEVEN DAYS AFTER POURING.

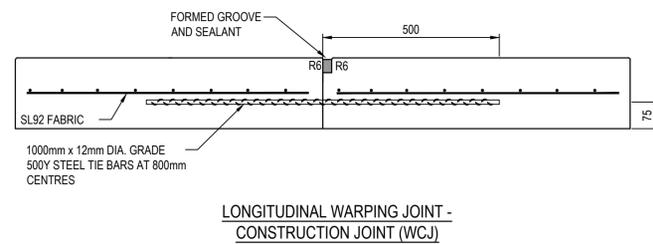
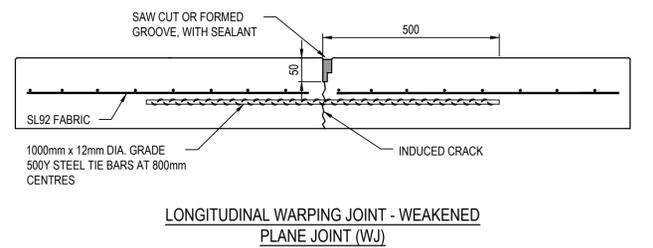
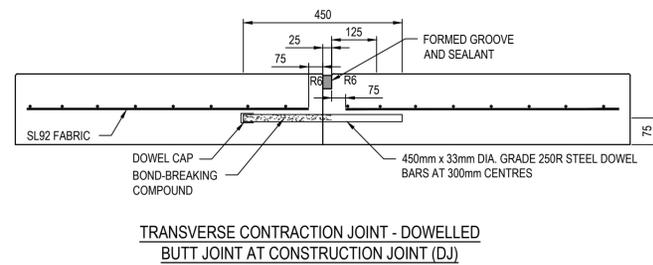
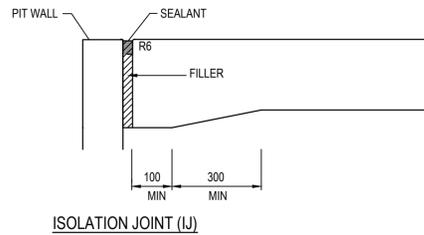

**CONCRETE JOINTING DETAILS**  
NOT TO SCALE

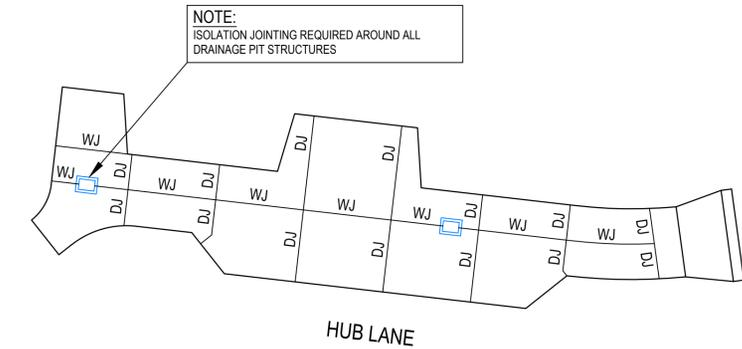
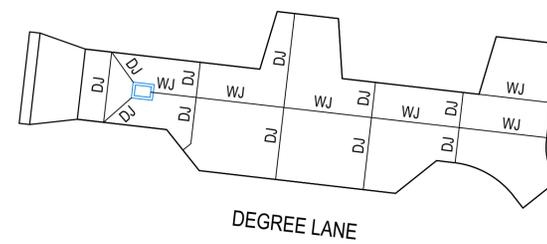

**PLAN**  
1:200

**NOTE:**  
ISOLATION JOINTING REQUIRED AROUND ALL DRAINAGE PIT STRUCTURES

REV	DATE	AMENDMENT / REVISION DESCRIPTION	DESIGN	APPROVAL
0	05.10.18	ISSUED FOR CONSTRUCTION	PM/RB	AB

All setting out should be carried out in accordance with MPA/Council's standard drawings or as nominated on hard copy plans provided by SMEC. Any digital information supplied by this office is for information only. Any discrepancies should be discussed with the superintendent.

Quality Management - ISO 9001  
 OHS Management - AS/NZS 1881  
 Environmental Management - ISO 14001

Global-Mark.com.au®

TITLE	NAME
DRAFTER	R.Barua
DESIGNER	P.McKay
CHECKED	Z.Gosev
AUTHORISED	A.Burrows
SMEC DRAWING REF.	1700E-04
MELBOURNE WATER REF.	388/3079

0 2 4 8  
Scale 1:200  
SCALE AS SHOWN AT A1

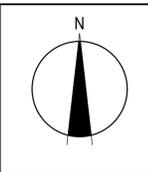

**SMEC**  
Member of the Surlana Jurong Group  
© ABN 47 065 475 149  
Tower 4, Level 20, 727 Collins Street  
Docklands, VIC 3008  
Ph 03 9514 1500



Olivine Estate - Stage 4  
Whittlesea City Council  
Road and Drainage  
Concrete Jointing Details

MELBOURNE REF <b>8 M2</b>	PROJECT / DRAWING No. <b>1700E-04-42</b>	SHEET No. <b>42 of 45</b>	REVISION <b>0</b>
------------------------------	---	------------------------------	----------------------

**LEGEND - LAYOUT PLAN**

ALL PROPOSED, FUTURE & EXISTING SERVICE LOCATIONS ARE SHOWN INDICATIVELY

	STORMWATER DRAIN, PIT & PROPERTY INLET
	SWALE DRAIN
	SEWER & MAINTENANCE STRUCTURES
	HOUSE DRAIN
	ELECTRICITY (U.GROUND)
	ELECTRICITY (O.HEAD)
	GAS
	TELSTRA
	WATER
	RECYCLE WATER
	AG. DRAIN
	SERVICE CONDUITS
	TACTILE PAVERS
	EXISTING STORMWATER DRAIN
	EXISTING MAIN DRAIN
	EXISTING SWALE DRAIN
	EXISTING SEWER & MAINTENANCE STRUCTURES
	EXISTING HOUSE DRAIN
	EXISTING ELECTRICITY (UNDER GROUND)
	EXISTING ELECTRICITY OVERHEAD
	EXISTING GAS
	EXISTING TELSTRA
	EXISTING WATER
	EXISTING RECYCLED WATER
	EXISTING AG. DRAIN
	EXISTING SERVICE CONDUITS
	EXISTING TACTILE PAVERS
	FUTURE STORMWATER DRAIN
	FUTURE MAIN DRAIN
	FUTURE SWALE DRAIN
	FUTURE SEWER & MAINTENANCE STRUCTURES
	FUTURE HOUSE DRAIN
	FUTURE ELECTRICITY (UNDER GROUND)
	FUTURE ELECTRICITY OVERHEAD
	FUTURE GAS
	FUTURE TELSTRA
	FUTURE WATER
	FUTURE RECYCLED WATER
	FUTURE AG. DRAIN
	FUTURE SERVICE CONDUITS
	ZERO LOT LINES
	141.34 EXISTING SURFACE LEVEL
	FS140.35 FINISHED BUILDING LINE LEVEL
	FR157.40 FINISHED RIDGE LINE LEVEL
	CH270.00 CHAINAGE
	TW159.60 TOP OF RETAINING WALL LEVEL
	BW159.00 BOTTOM OF RETAINING WALL LEVEL
	EXISTING RETAINING WALL
	FUTURE RETAINING WALL
	STRUCTURAL FILL > 200mm DEEP
	EXISTING STRUCTURAL FILL > 200mm DEEP
	CUT > 200mm DEEP
	DIRECTION OF FALL
	OVERLAND FLOW
	GRADED IN DIRECTION OF FALL TO LEVEL INDICATED
	EDGE STRIP, SUBSOIL DRAIN, "NO ROAD" SIGN & BARRIER
	EXISTING TREE TO BE RETAINED
	PERMANENT SURVEY MARK
	TEMPORARY BENCH MARK
	PROPOSED DRIVEWAY & FOOTPATH
	PROPOSED SHARED FOOTPATH
	PROPOSED ROAD PAVING
	EXISTING ROAD PAVING
	FUTURE PROPOSED WORKS 0.5m
	FUTURE PROPOSED WORKS 1 in 6 SLOPE VARIES
	FILL BATTER INTO FUTURE LOT NOT TO SCALE
	FUTURE PROPOSED WORKS 4m
	CUT BEHIND WALL IN FUTURE LOT NOT TO SCALE

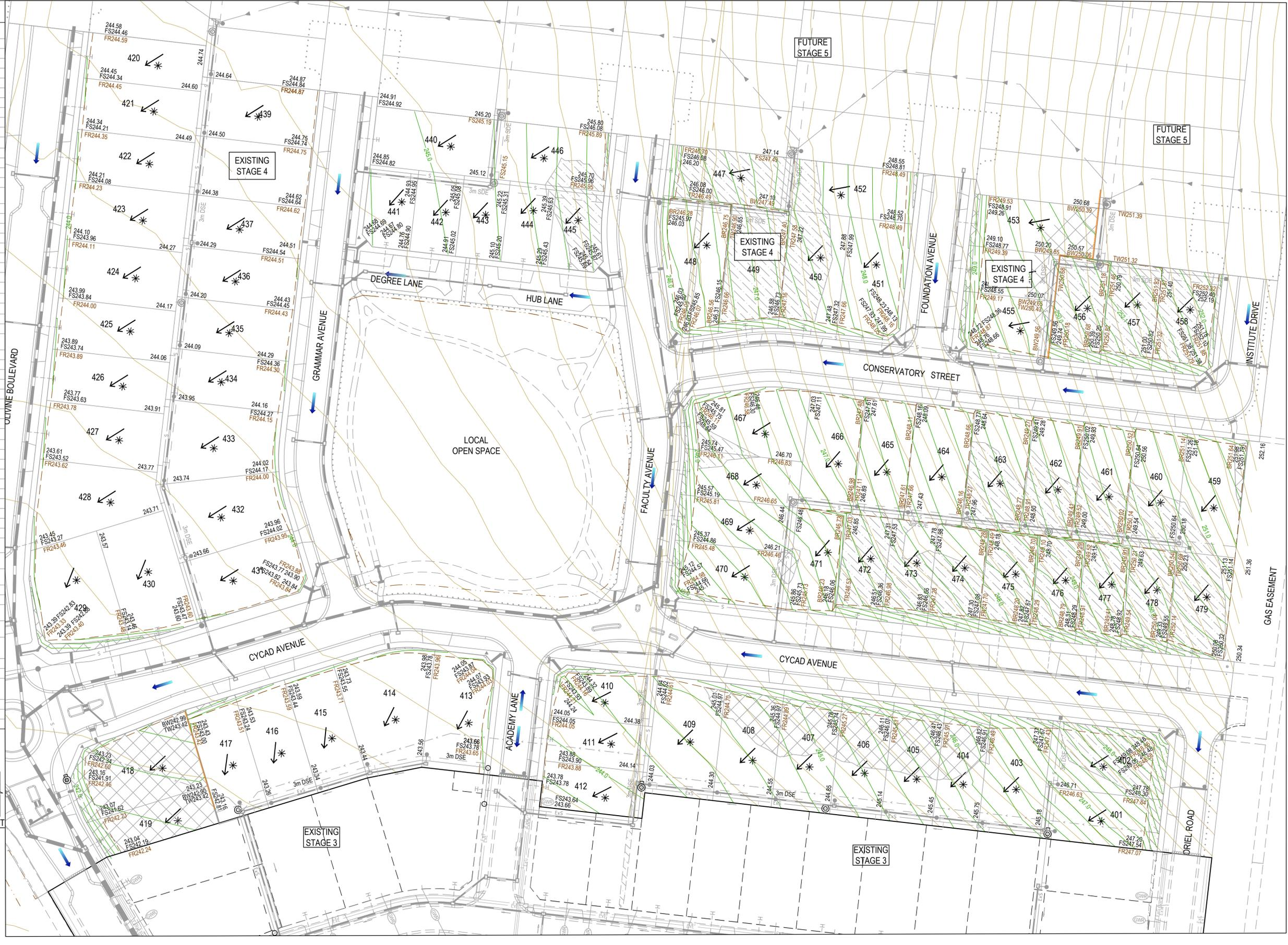

REV	DATE	AMENDMENT / REVISION DESCRIPTION	DESIGN	APPROVAL
0	05.10.18	ISSUED FOR CONSTRUCTION	PM/RB	AB

All setting out should be carried out in accordance with MPA/Council's standard drawings or as nominated on hard copy plans provided by SMEC. Any digital information supplied by this office is for information only. Any discrepancies should be discussed with the superintendent.

TITLE	NAME
DRAFTER	R.Barua
DESIGNER	P.McKay
CHECKED	Z.Gosev
AUTHORISED	A.Burrows
SMEC DRAWING REF.	1700E-04
MELBOURNE WATER REF.	388/3079

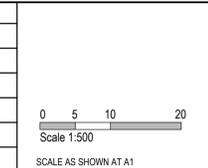

**SMEC**  
Member of the Surlana Jurong Group  
ABN 47 065 475 149  
Tower 4, Level 20, 727 Collins Street  
Docklands, VIC 3008  
Ph 03 9514 1500

**mirvac**

Olive Estate - Stage 4  
Whittlesea City Council  
Road and Drainage  
Earthworks & Retaining Wall Setout Plan

MELBOURNE REF 8 M2	PROJECT / DRAWING No. 1700E-04-43	SHEET No. 43 of 45	REVISION 0
-----------------------	--------------------------------------	-----------------------	---------------

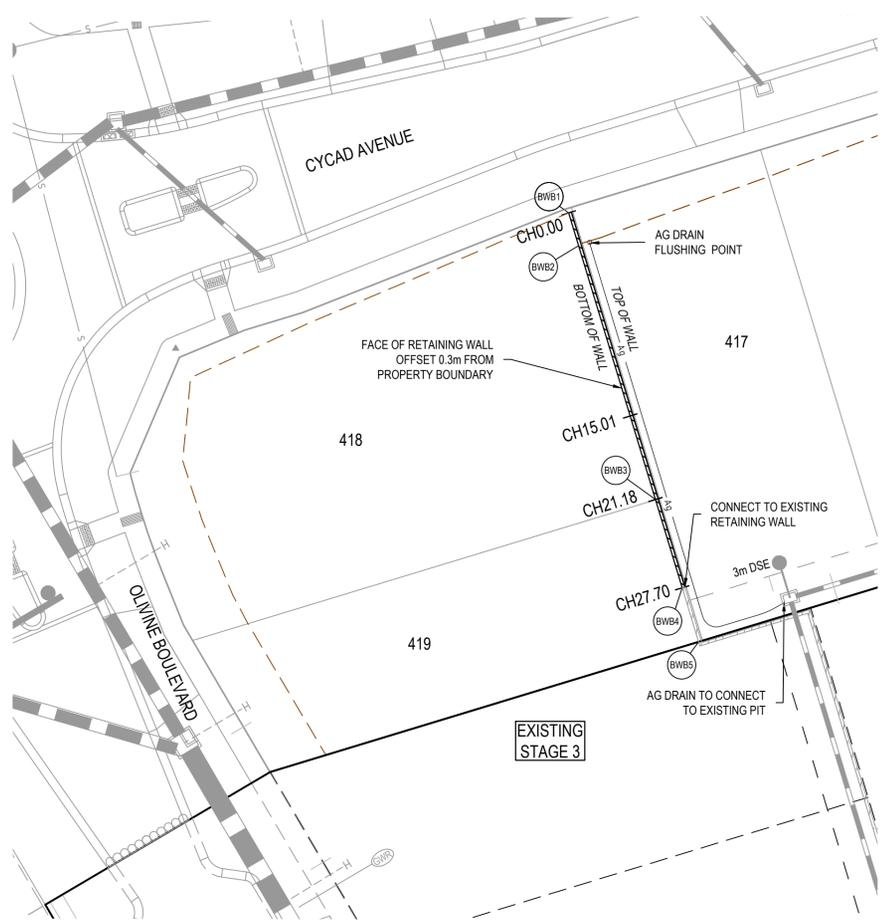

PLAN SCALE 1:250

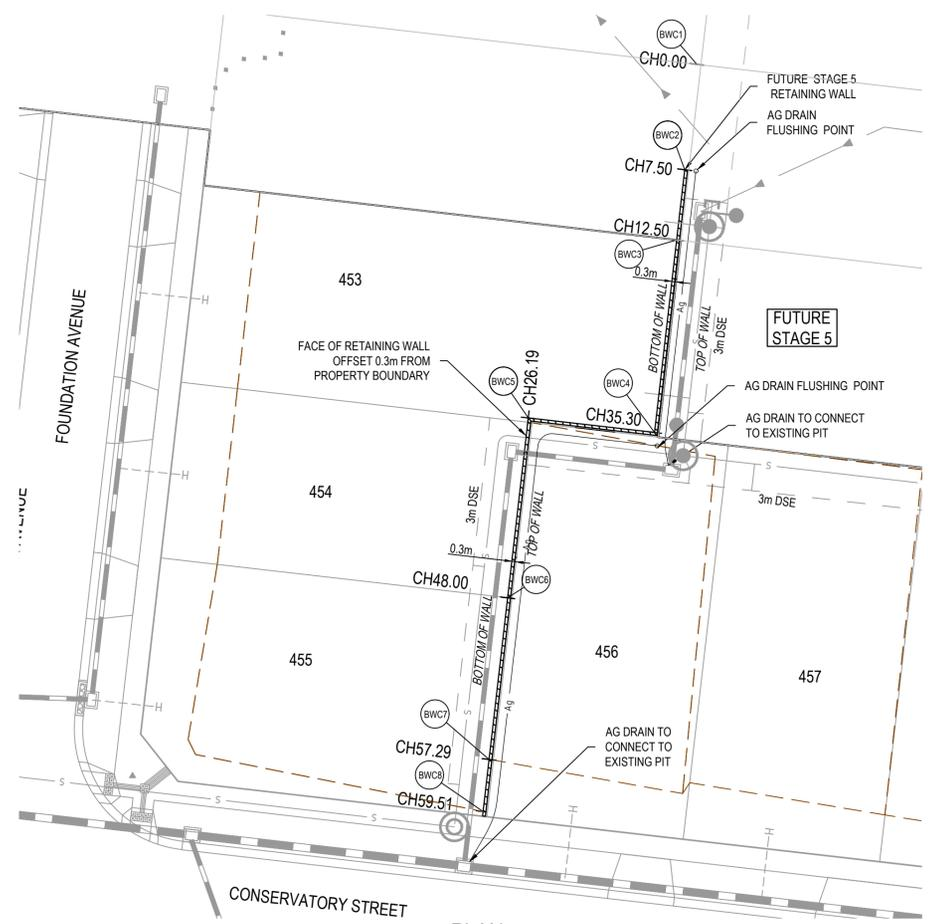

PLAN SCALE 1:250

**RETAINING WALL DESIGN AND APPROVALS REQUIREMENTS**

- NOTE: RETAINING WALL DETAILS AND DESIGN CERTIFICATION TO BE SUBMITTED TO COUNCIL PRIOR TO COMMENCEMENT OF CONSTRUCTION OF WALLS
- ROCK RETAINING WALLS**
- CONTRACTOR TO OBTAIN ANY RELEVANT BUILDING PERMITS. COPY OF BUILDING PERMIT TO BE PROVIDED TO PRINCIPAL.
  - CONTRACTOR TO PROVIDE STRUCTURAL ENGINEER INSPECTION AND CERTIFICATION FOR CONSTRUCTION OF ALL WALLS, IRRESPECTIVE OF NEED FOR PERMIT OR OTHERWISE.
  - CONTRACTOR TO ENSURE ALL REQUIREMENTS OF BUILDING PERMIT HAVE BEEN ADDRESSED.

**LEGEND**  
ALL PROPOSED, FUTURE & EXISTING SERVICE LOCATIONS ARE SHOWN INDICATIVELY

	STORMWATER DRAIN, PIT & PROPERTY INLET
	MAIN DRAIN
	SWALE DRAIN
	SEWER & MAINTENANCE STRUCTURES
	HOUSE DRAIN
	ELECTRICITY (U.GROUND)
	ELECTRICITY (O.HEAD)
	GAS
	TELSTRA
	OPTIC FIBRE
	WATER
	RECYCLE WATER
	AG DRAIN
	SERVICE CONDUITS
	CHAINAGE
	TOP OF RETAINING WALL LEVEL
	BOTTOM OF RETAINING WALL LEVEL
	EXISTING RETAINING WALL
	RETAINING WALL
	AG DRAIN

**LONGITUDINAL SECTION LEGEND**

	EXISTING SURFACE
	DESIGN LINE
	RETAINING WALL - CONCRETE SLEEPER

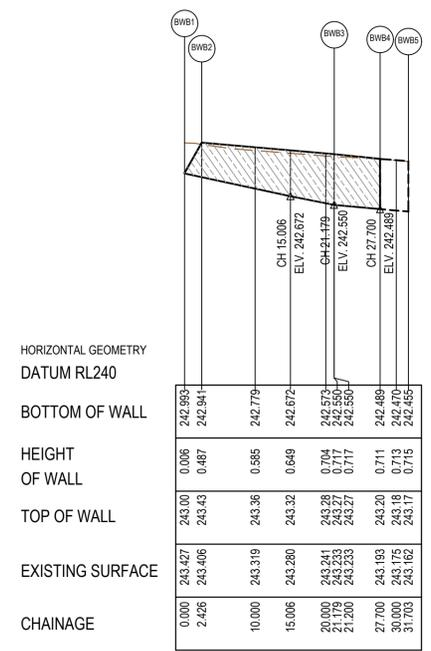

RETAINING WALL - LONGITUDINAL SECTION  
HORIZONTAL SCALE 1:500 @ A1  
VERTICAL SCALE 1:50 @ A1

**Alignment BWB**

Point no	Easting	Northing	RL
BWB1	323136.335	5843263.657	242.993
BWB2	323137.039	5843261.335	242.941
BWB3	323142.487	5843243.370	242.550
BWB4	323144.374	5843237.150	242.489
BWB5	323145.535	5843233.319	242.455

**Alignment BWC**

Point no	Easting	Northing	RL
BWC1	323385.839	5843412.549	250.530
BWC2	323384.983	5843405.098	250.444
BWC3	323384.412	5843400.131	250.380
BWC4	323382.848	5843386.521	249.890
BWC5	323373.907	5843387.548	249.742
BWC6	323372.446	5843374.832	249.648
BWC7	323371.131	5843363.390	249.585
BWC8	323370.707	5843359.708	249.565

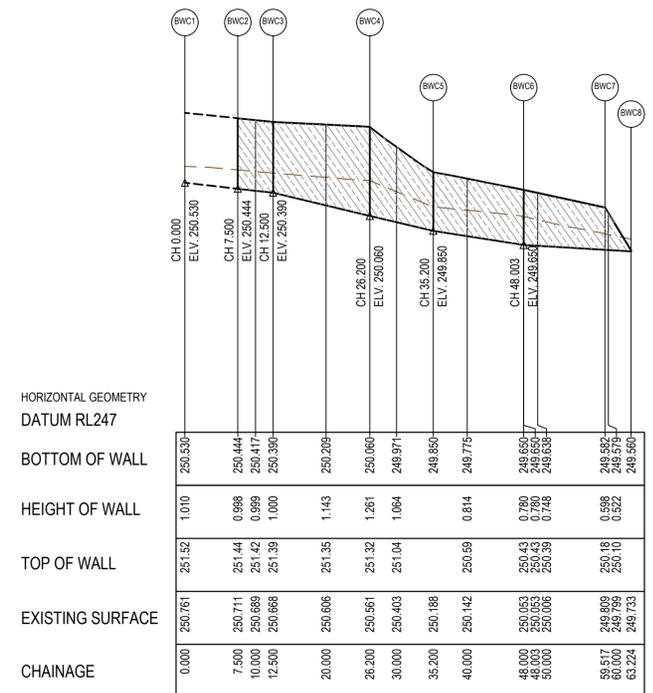

RETAINING WALL - LONGITUDINAL SECTION  
HORIZONTAL SCALE 1:500 @ A1  
VERTICAL SCALE 1:50 @ A1

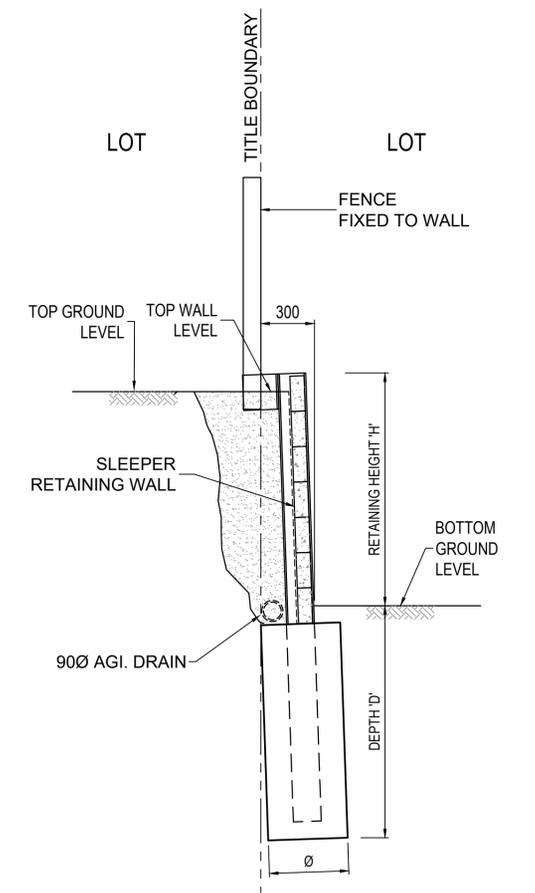

RETAINING WALL TYPICAL SECTION  
NOT TO SCALE

REV	DATE	AMENDMENT / REVISION DESCRIPTION	DESIGN	APPROVAL
0	05.10.18	ISSUED FOR CONSTRUCTION	PM/RB	AB

**ISSUED FOR CONSTRUCTION**

All setting out should be carried out in accordance with MPA/Council's standard drawings or as nominated on hard copy plans provided by SMEC. Any digital information supplied by this office is for information only. Any discrepancies should be discussed with the superintendent.

TITLE	NAME
DRAFTER	R.Barua
DESIGNER	P.McKay
CHECKED	Z.Gosev
AUTHORISED	A.Burrows
SMEC DRAWING REF.	1700E-04
MELBOURNE WATER REF.	388/3079

Scale 1:250  
Scale H1:500, V1:50  
Scale AS SHOWN AT A1

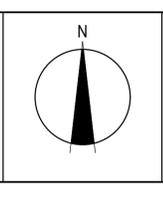

**SMEC**  
Member of the Surlana Jurong Group  
ABN 47 065 475 149  
Tower 4, Level 20, 727 Collins Street  
Docklands, VIC 3008  
Ph 03 9514 1500



Olivine Estate - Stage 4  
Whittlesea City Council  
Road and Drainage  
Retaining Wall Longitudinal Sections

MELWAYS REF <b>8 M2</b>	PROJECT / DRAWING No. <b>1700E-04-44</b>	SHEET No. <b>44 of 45</b>	REVISION <b>0</b>
----------------------------	---	------------------------------	----------------------

PHASE	DISCIPLINE CODE	RISK REGISTER -Construction- Operations- Maintenance	POTENTIAL RISK	RISK OWNER	POTENTIAL CONSEQUENCES	POTENTIAL ELIMINATION MEASURE, DESIGN INITIATIVE or CONTROL (Identify any Standard or Code of practice used)	HOW ISSUE ADDRESSED IN DESIGN AND/OR CONSTRUCTION OF THE WORKS	IS THE RISK ELIMINATED YES/NO	Residual Risk Likelihood (0-5)	Residual Risk Consequence (0-5)	Residual Risk Rating	RESIDUAL RISK OWNER
			<b>Road Furniture / Roadside features</b>									
Construction	RD	#N/A	Construction close to live traffic	Contractor	Disruptions to live traffic, construction incident involving live traffic.	Provide safe temporary traffic control (TCP)	TCP provided within contract	N	5	3	15	Constructor
Construction	RD	#N/A	Culverts	Contractor	Potential risk from culverts under construction and height / fall hazards	Falling from a height	Temporary barriers to be provided	N	2	5	10	Constructor
Construction	US	#N/A	Utilities become a hazard within clear zones	Contractor	Vehicle conflict with utility / pit	Personal injury, vehicle damage	Sequence works and protect with temp barrier or traffic control (TCP)	N	1	5	5	Constructor
Operational	RD	#N/A	Sight Lines	Road Authority	Inadequate drivers response time.	Increased potential for accidents	Ensure design complies with relevant standard. Undertake thorough Safety Audit	N	1	4	4	Road Authority
Operational	LS	#N/A	Signs and street lights	Road Authority	Potential for drivers / riders to strike signs and street lights	Increased potential for accidents	Ensure design complies with relevant standard. Undertake thorough Safety Audit	N	1	4	4	Road Authority
Operational	RF	#N/A	Headwalls	Road Authority	Potential vehicle conflict within clear zone	Increased potential for accidents	Establish adequate clear zone provision	N	2	4	8	Road Authority
Operational	RD	#N/A	Culverts	Relevant Authority	Potential fall hazard during maintenance, by vehicles and pedestrians	Falling from a height	Barriers to be provided in accordance with road standards	N	2	5	10	Constructor
			<b>Retaining Walls</b>									
Construction	RW	#N/A	Retaining Wall Alignment	Contractor	Falling from height during construction or commissioning of walls and adjacent structures eg. sewer manholes	Falling from a height	Provide temporary and permanent fencing at top of wall.	N	1	1	1	Constructor
Operational	RW	#N/A	Retaining Wall Alignment	Road/ Local Authority	Lack of safe access/setback from road	Increased potential for accidents	Establish adequate and accessible clear zone provision. Provide guardrail where required	N	1	1	1	Authority
Operational	RW	#N/A	Retaining Wall Height	Road/ Local Authority	Potential for falling from height	Personal injury	Provide temporary and permanent fencing at top of wall.	N	1	5	5	Authority
Operational	RW	#N/A	Retaining Wall Design	Road/ Local Authority	Potential for wall failure	Increased potential for accidents	Structural design in accordance with standards, geotechnical conditions, end use and good practise.	N	1	5	5	Authority
			<b>Drainage</b>									
Operational	DR	#N/A	Grated Pits	Relevant Authority	Trip/fall hazard with large spaced grate	Increased potential for accidents	Provide pedestrian/bicycle friendly grates where applicable. Refer to pit schedule	N	3	2	6	Authority
Operational	DR	#N/A	Non Standard Large Pits	Relevant Authority	Potential for pit failure	Increased risk to maintenance crews/ vehicles	Structural design in accordance with relevant design principles.	N	1	4	4	Authority
Operational	DR	#N/A	Culvert Endwalls/Headwalls	Relevant Authority	Potential for falling from height	Increased potential for accidents	Fencing to be provided where culverts/headwalls are at height in accordance with relevant authority standards	N	1	4	4	Authority
Operational	DR	#N/A	Culvert Endwall/Headwall Outlets	Relevant Authority	Children playing in large pipes / watercourses and access for maintenance	Increased potential for accidents	Grate provided to authority standards	N	2	5	10	Authority
Maintenance	DR	#N/A	Access to Pits	Relevant Authority	Lack of safe access for maintenance	Increased risk to maintenance crews	Provide safe working conditions for maintenance. Provide safe landing/ access arrangements as per relevant authority standards	N	2	5	10	Authority
Maintenance	DR	#N/A	Deep Pits	Relevant Authority	Lack of safe entry for maintenance	Increased potential for accidents	Contractor to be certified for work in confined spaces, step irons to be provided to appropriate authority standards. Refer to pit schedule	N	1	5	5	Authority
Maintenance	DR	#N/A	Access to drains / culverts	Relevant Authority	Lack of safe access for maintenance	Increased risk to maintenance crews	Provide safe working conditions for maintenance. Access as approved by authority	N	2	3	6	Authority
			<b>Sewer</b>									
Construction	SE	#N/A	Sewer Manhole located adjacent to Retaining Wall Alignment	Contractor	Falling from height during construction or commissioning of adjacent sewer manholes	Falling from a height	Provide temporary fencing until such time that permanent fencing is constructed	N	1	1	1	Constructor
Maintenance	SE	#N/A	Deep Manholes	Relevant Authority	Lack of safe entry for maintenance	Increased potential for accidents	Contractor to be certified for work in confined spaces, landings and step access provided as per authority standards and schedule	N	1	5	5	Authority
Maintenance	SE	#N/A	Access to Manholes	Relevant Authority	Lack of safe access for maintenance	Increased risk to maintenance crews	Provide safe working conditions for maintenance. Manholes located in compliance with authority standards	N	1	5	5	Authority
Maintenance	SE	#N/A	Pump Station Access	Relevant Authority	Lack of safe access for maintenance	Increased risk to maintenance crews	Provide safe working conditions for maintenance	N	2	4	8	Authority
			<b>Electricity</b>									
Operational	ES	#N/A	Electrical Design	Relevant Authority	Location of assets within clear zones e.g. pits/ substations	Increased potential for accidents	Electrical designed by sub consultant with appropriate accreditation and in accordance with authority standards	N	2	3	6	Authority
			<b>Telstra</b>									
Operational	TE	#N/A	Telstra Design	Relevant Authority	Location of assets within clear zones e.g. pits	Increased potential for accidents	Telecommunications designed by authority consultant with appropriate accreditation and in accordance with authority standards	N	2	3	6	Authority
			<b>Water</b>									
Operational	WA	#N/A	Water Design	Relevant Authority	Location of assets within clear zones e.g. pits/ substations	Increased potential for accidents	Water pits designed in accordance with authority standards	N	2	3	6	Authority
			<b>Gas</b>									
Operational	GA	#N/A	Gas Design	Relevant Authority	Location of assets within clear zones e.g. pits/ substations	Increased potential for accidents	Water pits designed in accordance with authority standards	N	1	1	1	Authority

REV	DATE	AMENDMENT / REVISION DESCRIPTION	DESIGN	APPROVAL
0	05.10.18	ISSUED FOR CONSTRUCTION	PM/RB	AB

All setting out should be carried out in accordance with MPA/Council's standard drawings or as nominated on hard copy plans provided by SMEC. Any digital information supplied by this office is for information only. Any discrepancies should be discussed with the superintendent.

TITLE	NAME
DRAFTER	R.Barua
DESIGNER	P.McKay
CHECKED	Z.Gosev
AUTHORISED	A.Burrows
SMEC DRAWING REF.	1700E-04
MELBOURNE WATER REF.	388/3079



**SMEC**  
Member of the Surlana Jurong Group  
ABN 47 065 475 149  
Tower 4, Level 20, 727 Collins Street  
Docklands, VIC 3008  
Ph 03 9514 1500



Olivine Estate - Stage 4  
Whittlesea City Council  
Road and Drainage  
Safety In Design

**ISSUED FOR CONSTRUCTION**



MELBOURNE WATER REF.	388/3079
----------------------	----------

0 1 2 4  
0 0.5 1 2  
Scale H1:100, V1:50  
SCALE AS SHOWN AT 1

MELBOURNE WATER REF. 388/3079

MELWAYS REF. 8 M2

PROJECT / DRAWING No.	1700E-04-85	SHEET No.	45 of 45	REVISION	0
-----------------------	-------------	-----------	----------	----------	---